INSTALLATION, USE, MAINTENANCE
Translation of the original instructions

Kalea

EN English



Doc. No. H5035EN00
EDITION 1 01 - 2017

N&W GLOBAL VENDING S.p.A.
ad unico socio
Sede amministrativa e operativa: Via Roma 24
24030 Valbrembo (BG) Italia
Telefono +39 035 606111
Fax +39 035 606463
www.nwglobalvending.com

Sede legale: Via Tommaso Grossi 2
20121 Milano (MI) Italia

Cap. Soc. € 41.138.297,00 i.v.
Reg. Impr. MI, Cod. Fisc. e P. IVA: 05035600963
Reg. Produttori A.E.E.: IT08020000001054
Cod. identificativo: IT 05035600963
Valbrembo, 20/04/2016

**DICHIARAZIONE DI CONFORMITA'
DECLARATION OF CONFORMITY
DÉCLARATION DE CONFORMITÉ
KONFORMITÄTSEKTLÄRUNG
DECLARACIÓN DE CONFORMIDAD
DECLARAÇÃO DE CONFORMIDADE
VERKLARING VAN OVEREENSTEMMING**



Italiano Si dichiara che la macchina, descritta nella targhetta di identificazione, è conforme alle disposizioni legislative delle Direttive Europee elencate a lato e successive modifiche ed integrazioni.

English The machine described in the identification plate conforms to the legislative directions of the European directives listed at side and further amendments and integrations

Français La machine décrite sur la plaquette d'identification est conforme aux dispositions légales des directives européennes énoncées ci-contre et modifications et intégrations successives

Deutsch Das auf dem Typenschild beschriebene Gerät entspricht den rechts aufgeführten gesetzlichen Europäischen Richtlinien, sowie anschließenden Änderungen und Ergänzungen

Español Se declara que la máquina, descrita en la etiqueta de identificación, cumple con las disposiciones legislativas de las Directrices Europeas listadas al margen y de sus sucesivas modificaciones e integraciones

Português Declara-se que a máquina, descrita na placa de identificação está conforme as disposições legislativas das Diretrizes Europeias elencadas aqui ao lado e sucessivas modificações e integrações

Nederlands De machine beschreven op het identificatieplaatje is conform de wetsbepalingen van de Europese Richtlijnen die hiernaast vermeld worden en latere amendementen en aanvullingen

Italiano Le norme armonizzate o le specifiche tecniche (designazioni) che sono state applicate in accordo con le regole della buona arte in materia di sicurezza in vigore nella UE sono:

English The harmonised standards or technical specifications (designations) which comply with good engineering practice in safety matters in force within the EU have been applied are:

Français Les normes harmonisées ou les spécifications techniques (désignations) qui ont été appliquées conformément aux règles de la bonne pratique en matière de sécurité en vigueur dans l'UE sont :

Deutsch Die harmonisierten Standards oder technischen Spezifikationen (Bestimmungen), die den Regeln der Kunst hinsichtlich den in der EU geltenden Sicherheitsnormen entsprechen, sind:

Español Las normas armonizadas o las especificaciones técnicas (designaciones) que han sido aplicadas de acuerdo con las reglas de la buena práctica en materia de seguridad vigentes en la UE son:

Português As normas harmonizadas ou as especificações técnicas (designações) que foram aplicadas de acordo com boas regras de engenharia em matéria de segurança em vigor na UE são:

Nederlands De geharmoniseerde normen of technische specificaties (aanwijzingen) die toegepast werden volgens de in de EU van kracht zijnde eisen van goed vakmanschap inzake veiligheid zijn de volgende:

Il fascicolo tecnico è costituito presso:

The technical file is compiled at:

N&W GLOBAL VENDING S.p.A.

**Targhetta di identificazione
Identification label**

Direttive europee European directives	Sostituita da Repealed by
2006/95/CE	2014/35/EU
2006/42/EC	
97/23/EC	
2004/108/EC	2014/30/EU
90/128/EC	2002/72/CE+ 2008/39/CE
80/590/EEC and 89/109/EEC	EC 1935/2004
EC 10/2011	
2002/95/EC	2011/65/EC
2002/96/CE	2012/19/UE

**Norme armonizzate / Specifiche tecniche
Harmonised standards / Technical specifications**

EN 60335-1:2002 + A1:2004 + A11:2004 + A12:2006
+ A2:2006+ A13:2008
EN 60335-2-75:2004 + A1:2005 + A11:2006 +
A2:2008 + A12:2010
EN 62233:2008
EN 55014-1: 2006 + A1: 2009 + A2:2011
EN 55014-2: 1997 + A1: 2001 + A2: 2008
EN 61000-3-2: 2014
EN 61000-3-3: 2013

ANDREA ZOCCHI

C.E.O

Declaration of conformity

CE The declaration of conformity is issued under the manufacturer's sole responsibility. The declaration of conformity with the European Directives and Standards provided for by the laws in force is supplied by the first page of this manual, which is an integral part of the machine.

- The legal provisions of the European Directives in force (with the subsequent amendments and integrations thereof)
- The harmonised standards in force
- The technical specifications (designations) applied in compliance with the safety rules of good practice enforced in the EU and listed on the same page.

INTEGRATION OF RADIO MODULES

In compliance with Article 17 of Directive 2014/53/EU (RED), the manufacturer checks whether the radio equipment is in compliance with the essential requirements of article 3 of the Directive.

The procedure used to check compliance is at the manufacturer's discretion. If a radio module is built in a "non-radio" equipment, the subject integrating the module will become the manufacturer of the end product and it must therefore check the compliance of the end product with the essential requirements of the 2014/53/EU (RED) Directive.

As a matter of fact, the integration of radio modules in other products can influence the compliance of the end product with the essential requirements of the Directive.

DEFINITIONS ACCORDING TO THE LAW

The **manufacturer** is a natural person who or a public body which manufactures radio equipment and/or electric material or has it engineered, manufactured or marketed by putting its own trademark or name on it.

An **importer** or **distributor** who places radio equipment or electric material on the market by putting its own name or trademark becomes the manufacturer.

An **importer** or **distributor** who makes any change to radio equipment or electric material already placed on the market to such an extent that the said change may condition the compliance with the listed directives is held to be the manufacturer and it must therefore assume the relative obligations according to the said directives.

Symbology

The following symbols may be present inside the machines, according to models (signs of danger)



Attention: dangerous voltage
Power off before removing the cover



Attention
Danger of crushing your hands



Attention
Hot surface

The signs of danger must be readable and visible; they shall be neither hidden nor removed. Damaged or unreadable labels must be replaced.

Warnings

This document intended for the technical personnel is made available in the electronic format at the manufacturer's (reserved area web site).

FOR INSTALLATION

The installation and any subsequent maintenance operation shall be carried out by the personnel skilled and trained on the utilisation of the machine according to the rules in force

The use of kits and/or accessories not type-approved by the manufacturer can not guarantee the observance of safety standards, in particular for live parts.

The installer will be the sole person responsible for any damage improper installation may cause to the machine or to things and people.

The manufacturer declines all responsibility for the use of non type-approved components.

Assembly and any testing operation must be carried out by qualified personnel who have a specific knowledge of the machine operation from the point of view of electric safety and health rules.

The intactness of the machine and its compliance with the standards of relevant installations must be checked by skilled personnel at least once a year.

Package materials must be disposed of in observance of the environment.

For the vending machines of hot drinks only

The machine is equipped with an automatic washing system for the mixers with the relative water circuit and the brewing unit.

If the machine is not used for some time (weekends, etc.) even for pauses longer than two days, it is recommended to enable the automatic washing functions (e.g. before starting to use the VM).

FOR USE

The machine can be used by children over 8 years and by people having reduced physical, sensorial or mental skills under the supervision of people responsible for their safety or specifically trained on the use of the machine.

Children shall not be allowed to play with the machine by the people in charge of their supervision

Children shall not be allowed to clean or service the machine.

FOR THE ENVIRONMENT

Some tricks will help you to protect the environment:

- use biodegradable products to clean the machine;
- properly dispose of all the packages of the products used to fill and clean the machine;
- power off the machine during inactivity for energy saving.

FOR DISMANTLING AND DISPOSAL

When dismantling the machine, it is recommended to destroy the machine rating plate.



The symbol shows that the machine can not be disposed of as common waste, but it must be disposed of as it is established by the 2012/19/EU (Waste Electrical and Electronic Equipment - WEEE) European Directive and by the national laws arising out of it in order to prevent any negative consequence for environment and human health.

The differentiated collection of the machine at the end of its life is organised and managed by the manufacturer.

For the correct disposal of the machine contact the sales point where you have purchased the machine or our after-sales service.

The unlawful disposal of the machine implies the application of the administrative sanctions provided for by the rules in force.

Attention!

If the machine is equipped with a cooling system, the cooling unit contains HFC-R134a fluoridised greenhouse effect gas ruled by the Kyoto protocol, the total heating potential of which is equal to 1300.



THE INTERNATIONAL CERTIFICATION NETWORK

CERTIFICATE

IQNet and its partner
CISQ/IMQ-CSQ
hereby certify that the organization

N&W GLOBAL VENDING SPA

VIA ROMA 24 - 24030 VALBREMBO (BG)
VIA DEL CHIOSO 13 - 24030 MOZZO (BG)
VIA DELEDDA 16 - 24030 MAPELLO (BG)
VIA SALVO D'ACQUISTO 7/9 - 24050 GRASSOBBIO (BG)

for the following field of activities

Design and manufacturing of coffee-based drink and snack & food dispensers

Further clarifications regarding the applicability of ISO 9001:2015 requirements may be obtained by consulting the organization

has implemented and maintains a
Quality Management System
which fulfills the requirements of the following standard

ISO 9001:2015

Issued on: 2016 - 04 - 15

Expiry date: 2018 - 04 - 27

Registration Number: IT – 12979

The status of validity of the certificate can be verified at <http://www.cisq.com> or by e-mail to fedcisq@cisq.com



Michael Drechsel

President of IQNET



Ing. Claudio Provetti

President of CISQ

IQNet Partners*:

AENOR Spain AFNOR Certification France AIB-Vinçotte International Belgium APCER Portugal CCC Cyprus
CISQ Italy CQC China CQM China CQS Czech Republic Cro Cert Croatia DQS Holding GmbH Germany
FCAV Brazil FONDONORMA Venezuela ICONTEC Colombia IMNC Mexico Inspecta Certification Finland INTECO Costa Rica
IRAM Argentina JQA Japan KFQ Korea MIRTEC Greece MSZT Hungary Nemko AS Norway NSAI Ireland PCBC Poland
Quality Austria Austria RR Russia SIGE Mexico SII Israel SIQ Slovenia SIRIM QAS International Malaysia
SQS Switzerland SRAC Romania TEST St Petersburg Russia TSE Turkey YUQS Serbia

IQNet is represented in the USA by: AFNOR Certification, CISQ, DQS Holding GmbH and NSAI Inc.

* The list of IQNet partners is valid at the time of issue of this certificate. Updated information is available under www.iqnet-certification.com



THE INTERNATIONAL CERTIFICATION NETWORK

CERTIFICATE

IQNet and its partner

CISQ/IMQ-CSQ

hereby certify that the organization

N&W GLOBAL VENDING SPA

VIA ROMA 24 - 24030 VALBREMBO (BG)
VIA DEL CHIOSO 13 - 24030 MOZZO (BG)
VIA GRAZIA DELEDDA 16 - 24030 MAPELLO (BG)

for the following field of activities

Design, manufacturing by laser cutting, punching, bending, welding of coils and assembling operations, of electronical and electromechanical vending machines

has implemented and maintains a

Environmental Management System

which fulfills the requirements of the following standard

ISO 14001:2004

Issued on: 2016 - 04 - 03

Expiry date: 2019 - 05 - 14

Registration Number: IT – 8753

The status of validity of the certificate can be verified at <http://www.cisq.com> or by e-mail to fedcisq@cisq.com



Michael Drechsel

President of IQNET



Ing. Claudio Provetti

President of CISQ

IQNet Partners*:

AENOR Spain AFNOR Certification France AIB-Vinçotte International Belgium APCER Portugal CCC Cyprus
CISQ Italy CQC China CQM China CQS Czech Republic Cro Cert Croatia DQS Holding GmbH Germany
FCAV Brazil FONDONORMA Venezuela ICONTEC Colombia IMNC Mexico Inspecta Certification Finland INTECO Costa Rica
IRAM Argentina JQA Japan KFQ Korea MIRTEC Greece MSZT Hungary Nemko AS Norway NSAI Ireland PCBC Poland
Quality Austria Austria RR Russia SIGE Mexico SII Israel SIQ Slovenia SIRIM QAS International Malaysia
SQS Switzerland SRAC Romania TEST St Petersburg Russia TSE Turkey YUQS Serbia

IQNet is represented in the USA by: AFNOR Certification, CISQ, DQS Holding GmbH and NSAI Inc.

* The list of IQNet partners is valid at the time of issue of this certificate. Updated information is available under www.iqnet-certification.com



THE INTERNATIONAL CERTIFICATION NETWORK

CERTIFICATE

IQNet and its partner
CISQ/IMQ-CSQ
hereby certify that the organization

N&W GLOBAL VENDING SPA

VIA ROMA 24 - 24030 VALBREMBO (BG)
MOZZO (BG) – MAPELLO (BG) – GRASSOBBIO (BG)

for the following field of activities

Design, manufacturing by punching, bending, welding of coils and assembling operations, and sales of electrical and electromechanical vending machines

has implemented and maintains a
Management System
which fulfills the requirements of the following standard

BS OHSAS 18001:2007

Issued on: 2014 – 11 – 28

Expiry date: 2017 – 11 – 27

Registration Number: IT – 97010

The status of validity of the certificate can be verified at <http://www.cisq.com> or by e-mail to fedcisq@cisq.com



Michael Drechsel

President of IQNET



Ing. Claudio Provetti

President of CISQ

IQNet Partners*:

AENOR Spain AFNOR Certification France AIB-Vinçotte International Belgium ANCE-SIGE Mexico APCER Portugal CCC Cyprus
CISQ Italy CQC China CQM China CQS Czech Republic Cro Cert Croatia DQS Holding GmbH Germany
FCAV Brazil FONDONORMA Venezuela ICONTEC Colombia IMNC Mexico Inspecta Certification Finland IRAM Argentina
JQA Japan KFQ Korea MIRTEC Greece MSZT Hungary Nemko AS Norway NSAI Ireland PCBC Poland
Quality Austria Austria RR Russia SII Israel SIQ Slovenia SIRIM QAS International Malaysia
SQS Switzerland SRAC Romania TEST St Petersburg Russia TSE Turkey YUQS Serbia

IQNet is represented in the USA by: AFNOR Certification, CISQ, DQS Holding GmbH and NSAI Inc.

* The list of IQNet partners is valid at the time of issue of this certificate. Updated information is available under www.iqnet-certification.com

English

TABLE OF CONTENTS

	PAGE		PAGE
FOREWORD	2	OPERATION	27
TRANSPORT AND STORAGE	2	VARIABLE-DOSE COFFEE DOSER	30
WHAT TO DO SHOULD A MALFUNCTION OCCUR	3	DISPENSING MILK	31
APPLIANCE IDENTIFICATION AND FEATURES	3	DISPENSING HOT WATER FROM THE SPOUT	31
APPLIANCE POSITIONING	4	CALIBRATION CHECKS AND SETTINGS	32
		TOUCHSCREEN	33
TECHNICAL SPECIFICATIONS	4	OPERATION IN NORMAL USER STATUS	34
POWER CONSUMPTION	6	DISPENSING A BEVERAGE	34
		APPLIANCE STATUS	34
CLEANING AND LOADING	7	PROGRAMMING	35
MAIN SWITCH AND SAFETY MEASURES	7	ACCESSING THE PROGRAMMING MENUS	35
HYGIENE AND CLEANING	8	ENTERING VALUES	36
DISPENSING HOT BEVERAGES INTO OPEN CONTAINERS	9	DAILY ACTIONS	37
		SELECTION SETTINGS	37
CONTROLS AND INFORMATION	9	MACHINE SETTINGS	45
		MACHINE INFORMATION	50
LOADING PRODUCTS	10	ENERGY SAVING MODE	54
COFFEE BEANS	10	PAYMENT SYSTEMS	55
INSTANT PRODUCTS	10	IMPORT/EXPORT	58
PRE-GROUND COFFEE	11	SYSTEM	60
MILK	11		
INTERNALLY SUPPLIED TANK WATER	11		
		MAINTENANCE	63
PERIODICAL OPERATIONS	12	GENERAL INTRODUCTION	63
CLEANING THE RESIDUE CONTAINERS	12	MAIN SWITCH AND FUSE	63
CLEANING THE MIXER AND DIFFUSER	14	MAINTAINING THE BREWING UNIT	64
CLEANING THE NOZZLES AND SPOUTS	15	MAINTAINING THE BREWING UNIT	66
CLEANING THE BREWING UNIT	16		
CLEANING THE MILK TANK	16	PERIODICAL OPERATIONS	68
CLEANING THE WATER SUPPLY TANK	16	SANITISATION	68
SWITCHING THE MACHINE ON	17	CLEANING THE NOZZLES AND SPOUTS	70
		REMOVING THE PRODUCT CONTAINERS	71
WASH CYCLES	17	REMOVING THE SIDE AND REAR PANELS	72
RINSING THE COMPONENTS	18		
CAPPUCCINO MAKER WASH	18	CIRCUIT BOARD FUNCTIONS	72
BREWING UNIT WASH CYCLE	19	POWER SUPPLY	73
CLEANING THE TOUCHSCREEN	20	ACTIVATION BOARD	74
SERVICE SUSPENSION	20	BOILER THERMAL PROTECTION	75
		INSTALLING AND/OR UPDATING SOFTWARE	76
INSTALLATION	21	APPENDIX	77
UNPACKING THE APPLIANCE	21		
MAIN SWITCH AND SAFETY MEASURES	21		
DISCARDING THE SOLID AND LIQUID RESIDUES	22		
REMOVING THE PANELS	22		
WATER SUPPLY	23		
ELECTRICAL CONNECTION	25		
INITIAL START UP	26		
FIRST SANITISATION	26		

Foreword

The technical documentation forms an integral part of the appliance and must therefore accompany any movement or transfer of ownership in order to allow the various operators to further consult the documentation.

Before installing and using the appliance, the document contents need to be scrupulously read and understood, as the manual provides important information regarding installation safety, provisions of use and maintenance work.

The manual is divided into three chapters.

Chapter 1 describes the loading and routine cleaning operations to be performed in the areas of the appliance which can be accessed via a key-operated door, without needing to use other tools.

Chapter 2 contains the instructions needed for a correct installation and the information required to optimise the appliance's performance.

Chapter 3 describes the maintenance work which requires the use of tools to access potentially dangerous areas.

The operations described in Chapter 2 and Chapter 3 must solely be carried out by personnel with specific knowledge of the appliance's operation both from an electrical safety and hygiene point of view.

TRANSPORT AND STORAGE

TRANSPORTATION

Special care must be taken when handling the appliance in order to avoid causing damage to the appliance and people.

When handling the appliance, there is a risk of hands and/or feet being crushed: use appropriate gloves and work shoes.

Move the appliance using lifting equipment that is suitable for the size and weight of the appliance (e.g. a forklift).

Only staff who are qualified to use lifting equipment can use the equipment.

Avoid:

- Tipping over and/or tilting the appliance;
- Dragging or lifting the appliance with ropes or similar;
- Lifting the appliance with lateral grips;
- Shaking or tossing the appliance and its packaging.

STORAGE

The storage environment needs to be dry and of a temperature between 0 and 40°C. If the appliance freezes, it must be conditioned in environments with temperatures between 0 and 40°C.

Wait until the appliance's temperature reaches the same temperature as its surrounding environment before switching it on.

WHAT TO DO SHOULD A MALFUNCTION OCCUR

In most cases, technical problems can be solved by means of small interventions; we therefore suggest that this manual is read carefully before contacting the manufacturer.

If the anomalies or malfunctions cannot be solved, please contact:

N&W GLOBAL VENDING S. p. A.
Via Roma 24
24030 Valbrembo
Italy - Tel No. +39 035606111

APPLIANCE IDENTIFICATION AND FEATURES

Each appliance is identified by means of a specific serial number which can be found on the nameplate located on the internal side of the door.

The nameplate is the only one recognised by the manufacturer and contains all the information that allows the manufacturer to quickly and safely provide all kinds of technical information and easily manage the spare parts

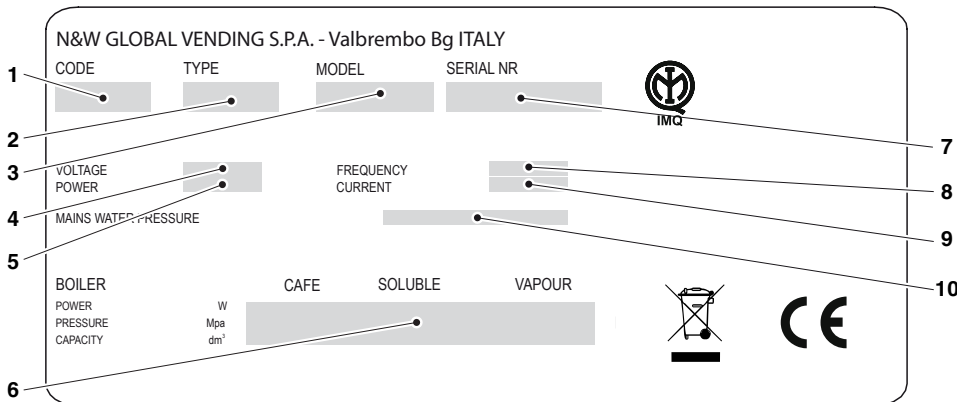

Fig. 1

1. Code
2. Type
3. Model
4. Supply voltage
5. Power
6. Boiler data
7. Serial number
8. Supply frequency
9. Supply voltage
10. Water mains properties

APPLIANCE POSITIONING

The appliance is not suitable for outdoor installations. It must be installed in a dry environment, with a temperature between 2°C and 32°C and cannot be installed in environments where jets of water are used for cleaning (e.g. large kitchens, etc.).

(i) The appliance must be installed in environments where it can be overseen by trained staff.

The appliance can be positioned close to a wall but there must be a gap of at least 4 cm between the wall and the appliance for ventilation purposes.

Under no circumstances should the machine be covered with cloths or similar.

The appliance must be placed on a level surface.

Important!

In the event of unscheduled maintenance work and/or repairs, the appliance must be able to be accessed from all sides.

Therefore, make sure that the appliance can be rotated so that the back and side panels can be removed.

TECHNICAL SPECIFICATIONS

DIMENSIONS

Height	783 mm
Width	368 mm
Depth	586 mm
Depth with door open	854 mm
Weight	44 kg
Weight (with cappuccinatore)	47 kg

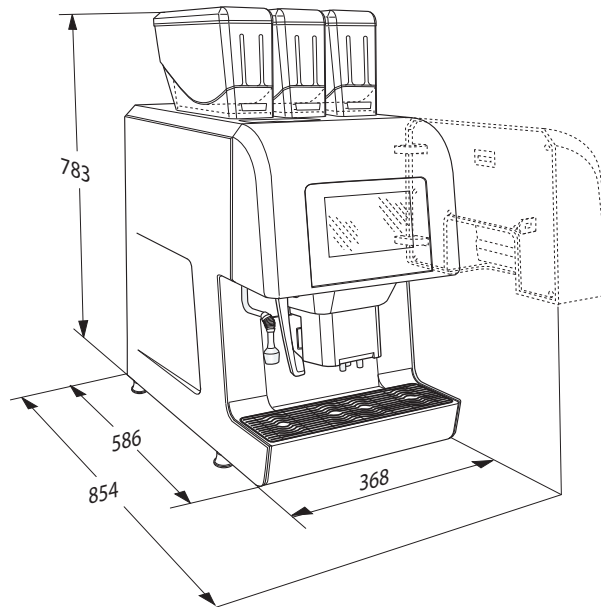

Fig. 2

ELECTRICAL CONNECTION

Voltage	230/240 V~
Frequency	50 Hz
Maximum current	13 A
Maximum power	3000 W

WATER SUPPLY

Mains water with a water pressure between 0.05 and 0.85 MPa (0.5 and 8.5 bar).

The appliance's software has been designed to control the water supply from an internal tank (optional kit).

LEVEL OF NOISE

The weighted continuous equivalent sound pressure level is less than 70 dB.

ESPRESSO ADJUSTMENTS

- Coffee grain size
- Coffee dose
- Water Dose

FRESH BREW ADJUSTMENTS

- Pre-ground product dose
- Water dose
- Infusion time

INSTANT ADJUSTMENTS

- Instant powder doses
- Water dose

MILK ADJUSTMENTS

For models with a cappuccino maker only.

- Amount of milk
- Milk flow rate
- Emulsion (on/off)
- Steam-heating milk (on/off)

TEMPERATURE ADJUSTMENT

Sets the temperature of boiler/s from the menu.

ENABLE SIGNS

- Water present
- Coffee present
- Brewing unit in position
- Boiler temperature reached

SAFETY MEASURES

- Product containers present
- Residue containers present
- Closed door sensor
- Boiler safety thermostats with a manual reset
- Main electric circuit protection device with fuse
- Steam boiler safety valve (models with a cappuccino maker only)

COUNTDOWN PROTECTION DEVICE OF THE:

- Coffee unit gearmotor
- Grinder(s)

THERMAL PROTECTION DEVICE OF THE:

- Coffee unit gearmotor
- Electromagnets
- Grinders
- Motor-doser
- Motor mixer
- Pump
- Milk pump (models with a cappuccino maker only)

CONTAINER CAPACITY

The containers have a 2-litre capacity. They can contain the approximate quantities of the following products:

- Approximately 1.1 kg of coffee beans
- Approximately 1.8 kg of instant chocolate
- Approximately 1.8 kg of ginseng
- Approximately 0.5 kg of instant barley

POWER CONSUMPTION

The power consumption of the appliance depends on many factors, such as the temperature and ventilation of the environment where the machine is located, the temperature of the inlet water, the temperature in the boiler, etc.

The calculated power consumption is indicative only.

A measurement at a room temperature of 22 °C was carried out and the following power consumption was detected:

Reaching the temperature	... Wh
24-hour standby	... Wh

ACCESSORIES AND KIT

The appliance can be fitted with accessories and kits in order to vary its performances:

The accessories and kits which can be attached to the appliance are available from the manufacturer.

The accessories and kits are supplied with installation and test instructions, which should be scrupulously followed in order to maintain the safety of the appliance.

The party that performed the installation is responsible for any damage that may occur to the appliance, or to things and people due to incorrect installation.

Important!

Accessories and kits which have not been approved by the manufacturer, may not comply with the safety standards, most especially in regards to live parts.

The manufacturer declines any responsibility if non-approved components are used.

The installation and subsequent test operations must be performed by qualified personnel, with specific knowledge of the appliance's operation both from an electrical safety and hygiene point of view.

Chapter 1 Cleaning and loading

The appliance is not suitable for outdoor installations. It must be installed in a dry environment, with a temperature between 2°C and 32°C and cannot be installed in environments where jets of water are used for cleaning (e.g. large kitchens, etc.).

MAIN SWITCH AND SAFETY MEASURES

MAIN SWITCH

The (manual) main switch cuts off the power to the appliance and is positioned behind the solid residue container.

When carrying out normal cleaning and product loading tasks, the appliance does not have to be switched off.

If the appliance needs to be switched off via the main switch, the residue container must be removed.

SAFETY MEASURES

The routine cleaning and product loading tasks can be performed safely.

The unit has magnetic sensors which detect:

- The closing of the door
- The presence of the containers
- The presence of the residue containers

In the absence of one of the listed conditions, the appliance is disabled.

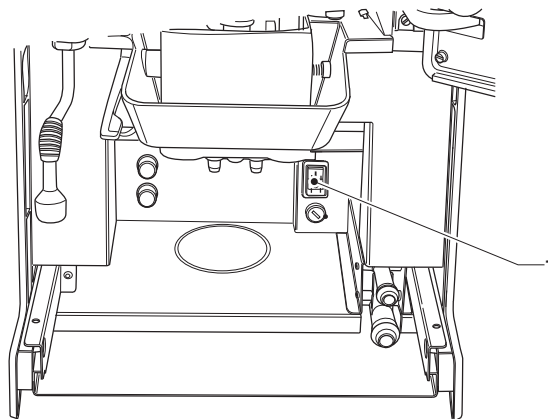

Fig. 3

1. Main switch

HYGIENE AND CLEANING

This manual shows the potential weak points and includes information about controlling the possible growth of bacteria.

Under the current health and safety regulations, the operator of the appliance must apply the self-control procedures, identified in accordance with the HACCP (Hazard Analysis Critical Control Point) Directive and national legislation.

It is also a good idea to sanitise the surfaces which do not come into direct contact with the food inside the appliance, as well as the side modules (cup warmers, coolers, etc.).

The sanitisation must be performed using disinfectants, taking care to mechanically remove the residues and visible films using swabs and/or brushes.

Do not use solvents and/or strong-scented detergents.

Some parts of the appliance can be damaged by aggressive detergents.

The manufacturer shall not be held responsible for any damage caused due to the non-observance of the above or the use of aggressive or toxic chemical products.

Do not under any circumstances use water jets to clean the appliance.

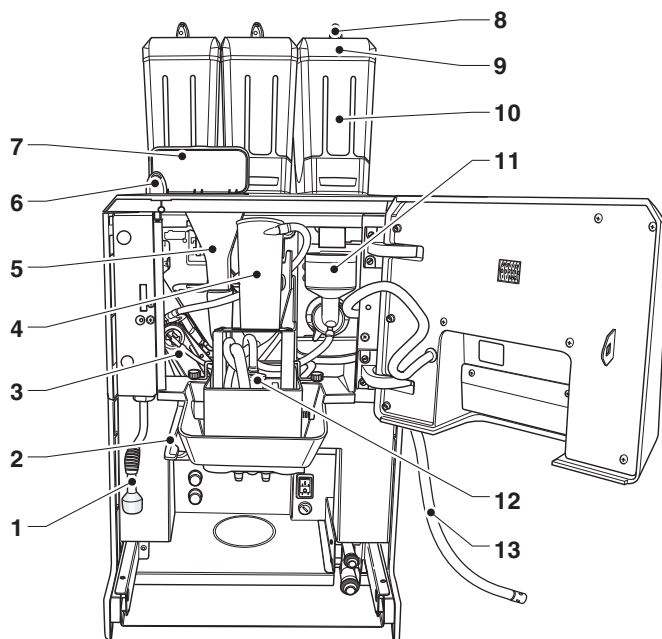

Fig. 4

1. HOT WATER NOZZLE*
2. Nozzle-moving handle
3. Brewing unit
4. Diffuser nozzle*
5. Decaffeinated coffee chute*
6. Door lock
7. Decaffeinated coffee door and door lock
8. Container lock*
9. Container cover
10. Product container
11. Mixer*
12. Milker nozzle
13. Milk hose**

* Certain models only.

** Models with a cappuccino maker only.

DISPENSING HOT BEVERAGES INTO OPEN CONTAINERS

(E.g. Plastic cups, ceramic cups, pitchers)

The machines that dispense beverages into open containers must be used exclusively for the sale and distribution of drinks which are produced via:

- Coffee infusion
- The reconstitution of instant or freeze-dried products.

These products must be declared by the manufacturer as "suitable for automatically dispensing" into open containers.

Models with cappuccino makers can also be used to dispense pasteurised or UHT milk which has been kept refrigerated and drawn from an external tank.

Products must be kept in strict accordance with the manufacturer instructions regarding storage, storage temperature and expiry date.

ⓘ The dispensed drinks should be consumed immediately and must, under no circumstances be stored and/or packaged for later consumption.

Any other use is considered improper and therefore potentially dangerous.

CONTROLS AND INFORMATION

The appliance must operate at a room temperature between 2 and 32 °C.

The controls and information for the user are on the external side.

All messages destined for the user are shown on the appliance's display.

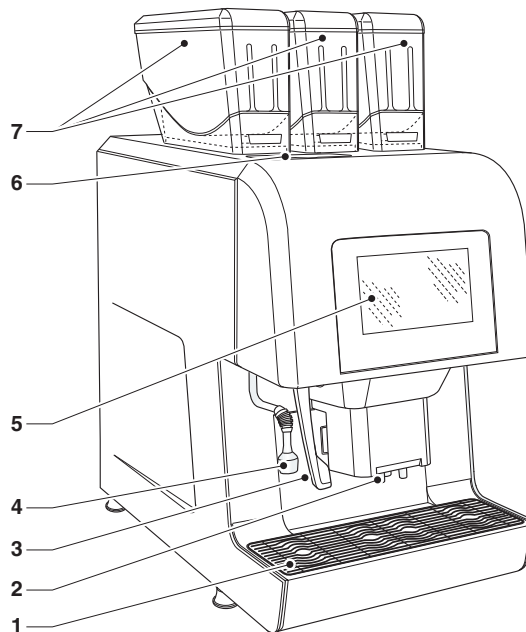

Fig. 5

1. Liquid residue container
2. Dispensing nozzles
3. Nozzle-moving handle
4. Hot water dispensing nozzle*
5. Touchscreen
6. Decaffeinated coffee door*
7. Product containers (2 or 3 depending on the model)

*Certain models only

LOADING PRODUCTS

Before loading the products, check that they have been stored in compliance with the manufacturer instructions regarding storage and the storage temperature.

Before loading the products, check the expiration date.

The products must be declared by the manufacturer as suitable for automatically dispensing into open containers.

Products may also be loaded with partially-full containers.

COFFEE BEANS

It is recommended to use high-quality coffee beans in order to avoid appliance failure due to the presence of impurities.

1. Open the container lid using the key (if present).
2. Fill the container with coffee beans.
3. Carefully close the lid.

Do not exceed the maximum capacity of the containers; the maximum level of the containers coincides with the support point of the lid.

INSTANT PRODUCTS

It is recommended to use high-quality instant products in order to avoid appliance failure due to the presence of impurities.

1. Open the instant powder container lid using the key (if present).
2. Fill the container with instant powder.
3. Carefully close the lid.

Avoid compressing the powder in order to prevent it from packing up.

Make sure that the instant products do not contain any clumps.

Do not exceed the maximum capacity of the containers; the maximum level of the containers coincides with the support point of the lid.

PRE-GROUND COFFEE

For models with pre-ground coffee only. It is recommended to use high-quality pre-ground coffee in order to avoid appliance failure due to the presence of impurities.

1. Open the container lid using the key (if present). Do not exceed the maximum capacity of the containers; the maximum level of the containers coincides with the support point of the lid.
2. Carefully close the lid.
3. Fill the container with pre-ground coffee.
4. Carefully close the lid.

Do not exceed the maximum capacity of the containers; the maximum level of the containers coincides with the support point of the lid.

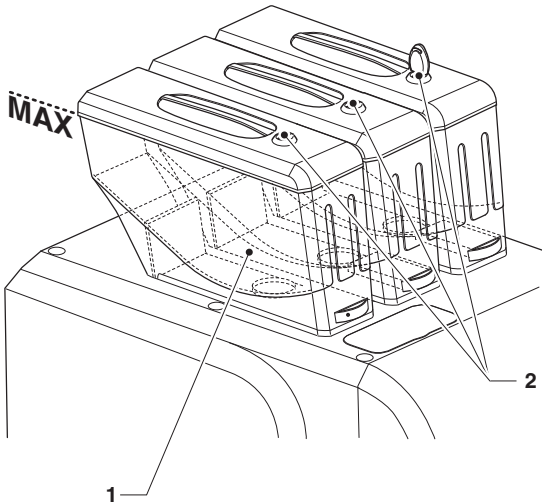

Fig. 6

1. Container
2. Container lock*

*Certain models only

MILK

For models with a cappuccino maker only. The milk is drawn via a pipe from the milk container.

Only use pasteurised or UHT (Ultra High Temperature) milk.

With regards to preserving milk, carefully follow the manufacturer's holding temperature instructions and check the product's expiry date.

ⓘ To prevent flow problems, place the milk container on the same surface as the appliance.

The suction hose must rest on the bottom of the milk container and not be looped.

The milk must be managed in compliance with the food safety and hygiene requirements.

Do not exceed the milk tank's maximum capacity; the maximum level is indicated on the tank with a reference mark.

INTERNALLY SUPPLIED TANK WATER

For models with an internally supplied water tank only.

Every day, when the machine is first turned on, the tank must be emptied of any residual water and sanitised when the no water warning appears, whilst making sure to mechanically remove any residues and visible films using swabs or brushes, if necessary.

To restore service:

1. Fill the tank with clean drinking water which is clear and free from impurities.
2. Connect the tank to the appliance.
3. Confirm the reset operation.

Do not exceed the tank's maximum capacity; the maximum level is indicated on the tank with a reference mark.

PERIODICAL OPERATIONS

This manual shows the potential weak points and includes information about controlling the possible growth of bacteria.

Under the current health and safety regulations, the operator of the appliance must apply the self-control procedures, identified in accordance with the HACCP (Hazard Analysis Critical Control Point) Directive.

For each product load or more frequently, depending on how often the appliance is used, the incoming water quality and the products used, it is necessary to clean and sanitise the appliance and parts that come into contact with the food, by proceeding as described in the following paragraphs.

Apart from the external parts of the brewing units and mixers which need to be cleaned so that any powder residue is removed, especially in the funnel area, the parts of the mixer which come into contact with the beverage should also be sterilised.

Do not under any circumstances use jets of water directly on the appliance when cleaning.

CLEANING THE RESIDUE CONTAINERS

The residue containers can be easily removed to make emptying and cleaning easier.

The residue containers must be cleaned with the machine switched on and the door closed.

LIQUID RESIDUES

The liquid residue container can be easily removed, even if it is directly connected to a drain in the mains.

Pull on the liquid residue container to remove it.

If the liquid residue container is not directly connected to a drain in the mains, it will need to be emptied on a regular basis.

Proceed to sanitise the container.

SOLID RESIDUES

MODELS WITH A SOLID RESIDUE CONTAINER

The appliance control software notifies when the maximum number of dispenses has been reached.

The selections which involve coffee are disabled.

To remove the solid residue container, the dispensing nozzles must be lifted up using the movement lever.

1. Empty and wash the containers with a sanitising solution.
2. Reset the solid residue counters to zero (solid residue container empty function).

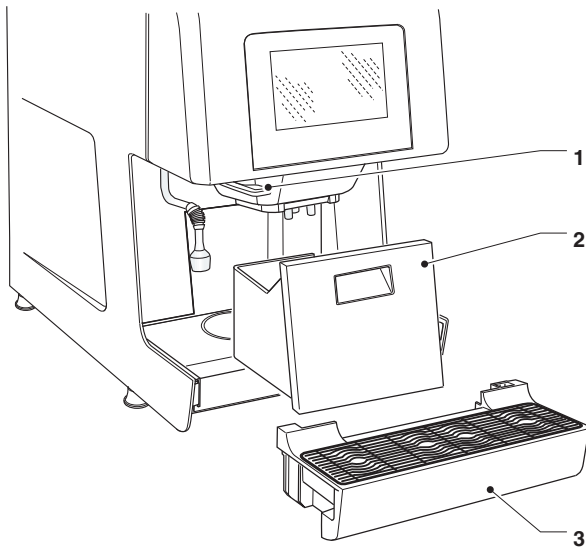

Fig. 7

1. Nozzle-moving handle
2. Solid residue container
3. Liquid residue container

MODELS WITH SOLID RESIDUE DISCHARGE ON THE BENCH

Proceed as follows:

1. Lift the dispensing nozzles using the movement lever.
2. Remove the liquid residue container.
3. Remove the solid residue chute cover.
4. Empty and clean the solid residue container.
5. Wash the solid residue chute to remove any coffee residue.
6. Reinsert the residue chute and the residue container.

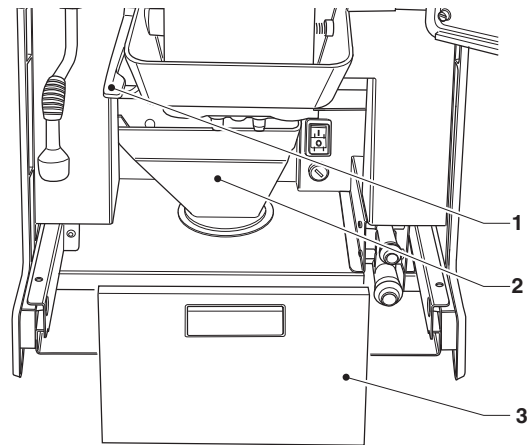

Fig. 8

1. Nozzle-moving handle
2. Solid residue chute
3. Solid residue chute cover

CLEANING THE MIXER AND DIFFUSER

After each load and/or on a weekly or more frequent basis, depending on how often the appliance is used, the quality of the incoming water and the products used, the mixers must be sanitised.

The parts that need to be cleaned are: The powder deposit trays, instant drink dispensing mixers and pipes and the diffuser.

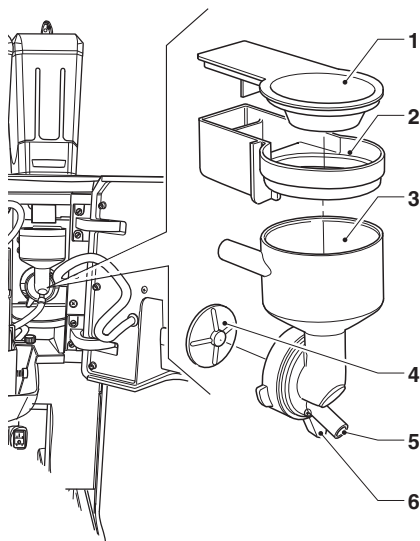

Fig. 9

1. Instant powder funnel
2. Instant powder tray
3. Water funnel
4. Mixer fan
5. Instant beverage hose connection
6. Mixer locking ring

To clean the mixer, proceed as follows:

1. Disconnect the instant beverage hose from the connection of the water funnel.
2. Turn the water funnel locking ring anti-clockwise and remove the mixer from the appliance.
3. Separate all the components (the instant products funnels, the water funnels, the conveyors, the powder trays).
4. Remove the fans: block the disk fitted on the motor mixer shaft with one finger, then unscrew the mixer fan.

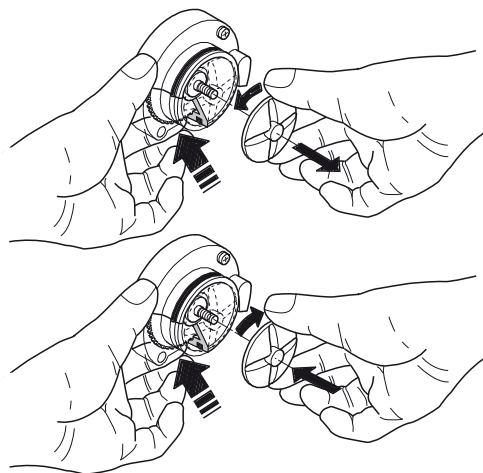

Fig. 10

5. Soak the components for about 20 minutes in a container filled with a pre-prepared sanitising solution, whilst taking care to mechanically remove the residues and visible films using swabs or brushes if necessary.
6. Rinse thoroughly and dry each part carefully.
7. Reassemble the fans.
8. Reassemble the mixer parts and correctly reposition the water funnel. Check that it has been correctly inserted.

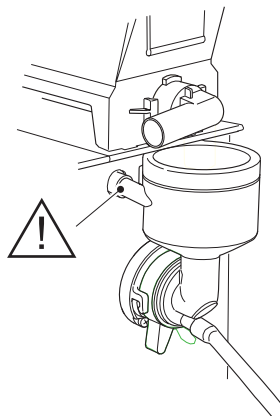

Fig. 11

- Turn the water funnel locking ring clockwise in order to secure the mixer to the appliance.

After installing the components, it is necessary to:

- Wash the mixer and add a few drops of the sterilising solution into the various funnels.
- Then thoroughly rinse the components in order to remove any sterilising solution residue.

CLEANING THE NOZZLES AND SPOUTS

Weekly or more frequently, depending on how often the appliance is used and the quality of incoming water, it is necessary to sanitise the instant beverage dispensing ducts and nozzles.

To clean the nozzles, proceed as follows:

- Pull down the nozzle-moving handle.
- Remove the cover and disconnect the hoses from the nozzles.
- Disconnect the coffee dispensing hose from the flow divider nozzle.
- Unhook the flow divider nozzle from the nozzle support.
- Remove the flow divider, milker nozzle (if present) and the instant beverage nozzles.
- For models with a cappuccino maker, separate all the parts of the milker nozzle.
- Proceed to sanitise all the components, taking care to mechanically remove residues and visible films using swabs or brushes, if necessary.
- Clean the spouts (if present) with a cloth that has been dampened with sanitising solution.

MODELS WITH A CAPPUCCINO MAKER

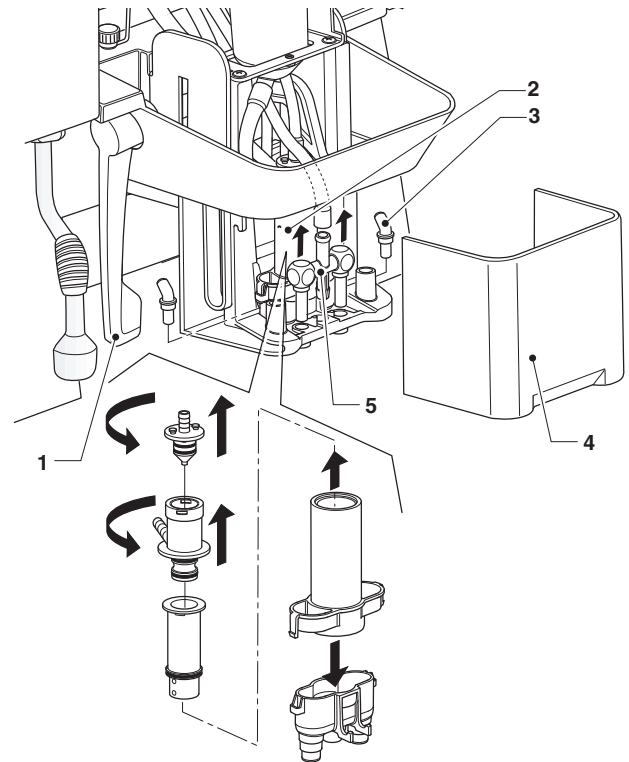

Fig. 12

- Nozzle-moving handle
- Milker nozzle
- Instant beverage nozzles
- Movable nozzle cover
- Flow divider nozzle

MODELS WITHOUT A CAPPUCCINO MAKER

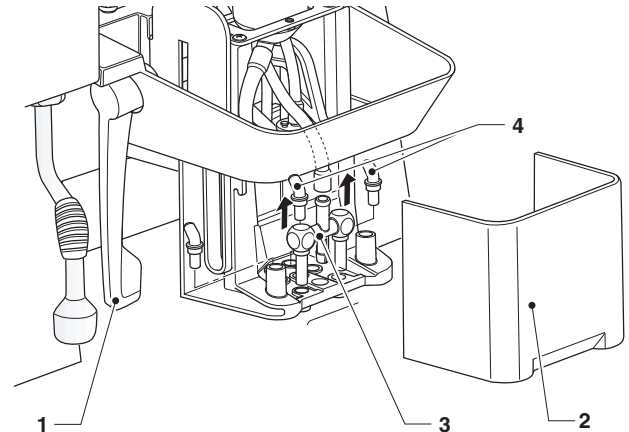

Fig. 13

- Nozzle-moving handle
- Movable nozzle cover
- Coffee nozzle
- Instant beverage nozzles

DIFFUSER NOZZLE

For models with a diffuser nozzle only.

1. Unhook the diffuser nozzle from the support bracket.
2. Separate the diffuser nozzle components.
3. Start sanitising whilst taking care to mechanically remove residues and visible films using swabs or brushes, if necessary.
4. Thoroughly rinse the various components before reassembling them.

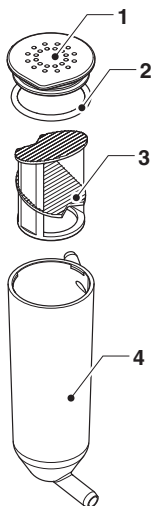

Fig. 14

1. Cover
2. Seal
3. Diffuser
4. Diffuser nozzle body

CLEANING THE BREWING UNIT

After each load or at least once a week, it is good practice to clean the external parts of the brewing unit by removing any powder residue, especially in the funnel, filter and scraper areas.

CLEANING THE MILK TANK

For models with a cappuccino maker only.

Every day or at the end of the final shift of the day, the milk tank must be emptied of any residues and sanitised, whilst taking care to mechanically remove residues and visible films using swabs or brushes if necessary.

CLEANING THE WATER SUPPLY TANK

For models with an internally-supplied water tank only.

Every day, when the appliance has finished being used, the internally-supplied water tank must be emptied of any residual water and sanitised, whilst making sure to mechanically remove any residues and visible films using swabs or brushes if necessary.

SWITCHING THE MACHINE ON

Every time you switch on the appliance, it performs initial checks by dispensing hot water and steam from the nozzles.

(i) Only models with a cappuccino maker require the cappuccino maker to be washed (with detergent) if this has not been carried out in the last few hours.

A screen appears showing the heating status of the boilers.

The selections are not available until the appliance has reached its operating temperatures.

Upon reaching the operating temperature a white screen is displayed with the icons and the invitation to select a beverage.

WASH CYCLES

The appliance has been designed to perform wash cycles on the main functional units.

⚠ During the wash cycles, hot water comes out of the nozzles, which poses a risk of injury to people.

⚠ Do not place your hands in the dispensing area during the wash cycle: there is a danger of scalding.

(i) The wash cycles do not replace the need to disassemble the components for regular sanitisation.

ACCESSING THE WASH FUNCTIONS

To access:

1. Touch WASHES  when the door is closed.
2. Select the components that require washing.

For appliances that do not have a drainage system for the liquid residue containers, it is recommended to place a container with a capacity of at least 3 litres under the nozzles.

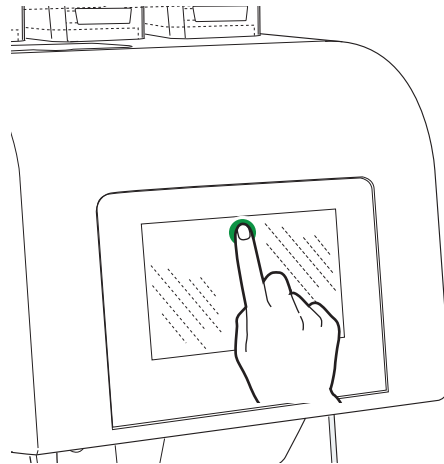

Fig. 15

RINSING THE COMPONENTS

Start the rinse cycle (with hot water only) of the various components (mixer, brewing unit, etc.).

(i) The rinse cycles do not replace the need to disassemble the components for regular sanitisation.

Remove the cups from the dispensing area.

⚠ Do not place your hands under the nozzles during the wash cycles: there is a danger of scalding.

For the entire duration of the rinse cycle, the selections will remain disabled.

CAPPUCCINO MAKER WASH

For models with a cappuccino maker only. The guided wash of the cappuccino maker should be carried out each time that the appliance has finished being used for the day, or more frequently, depending on how often the appliance is used.

When the cappuccino maker needs to be cleaned (with detergent), it signals when the time limits and/or number of selections have been reached.

(i) Milk-based beverages cannot be dispensed until the cappuccino maker wash cycle is performed.

Only use cappuccino maker-specific products.

⚠ When using these products, strictly follow the manufacturer's instructions on storage, handling, dosing and use; carefully read the safety instructions.

When using generic products, there is no guarantee that they are hygienic, will not alter the taste of the beverages, or will have no consequences on human health.

For appliances that do not have a liquid residue drainage system, place a container with a capacity of at least 3 litres under the nozzles in order to collect the wash residues.

The appliance automatically prepares the washing mixture with the indicated amount of water.

It takes several minutes for the cappuccino maker to be washed.

⚠ The wash with detergent does not replace the need to disassemble the milker nozzle for regular sanitisation.

If for any reason the detergent cycle is interrupted (e.g. manual interruption, power failure, etc.), when the machine is restarted a new wash cycle of the cappuccino maker is required.

Once the wash cycle has finished, the milk-based beverages will be available once again.

The finished wash cycle is stored by the appliance.

BREWING UNIT WASH CYCLE

The brewing unit wash cycle should be carried out each time that the appliance has finished being used for the day, or more frequently, depending on how often the appliance is used.

When the brewing unit needs to be cleaned (with detergent), it signals when the time limits and/or number of selections have been reached.

i **Coffee-based beverages cannot be dispensed until the brewing unit wash cycle is performed.**

Only use coffee maker-specific products.

⚠ When using these products, strictly follow the manufacturer's instructions on storage, handling, dosing and use; carefully read the safety instructions.

When using generic products, there is no guarantee that they are hygienic, will not alter the taste of the beverages, or will have no consequences on human health.

For appliances that do not have a liquid residue drainage system, place a container with a capacity of at least 3 litres under the nozzles in order to collect the wash residues.

It takes several minutes for the brewing unit to be washed.

1. Insert the detergent chute (supplied as standard) into the decaffeinated coffee chute.

⚠ Always use the detergent chute to prevent detergent residue remaining in the decaffeinated coffee chute.

2. Add the detergent by dropping it into the detergent chute.
3. Start the detergent cycle.
4. When the cycle has finished, remove the detergent chute.

Warning!

If for any reason the detergent cycle is interrupted (e.g. manual interruption, power failure, etc.), when the machine is restarted a new rinse cycle is required in order to remove any residues from the detergent cycle.

Once the wash cycle has finished, the coffee-based beverages will be available once again.

The finished wash cycle is stored by the appliance.

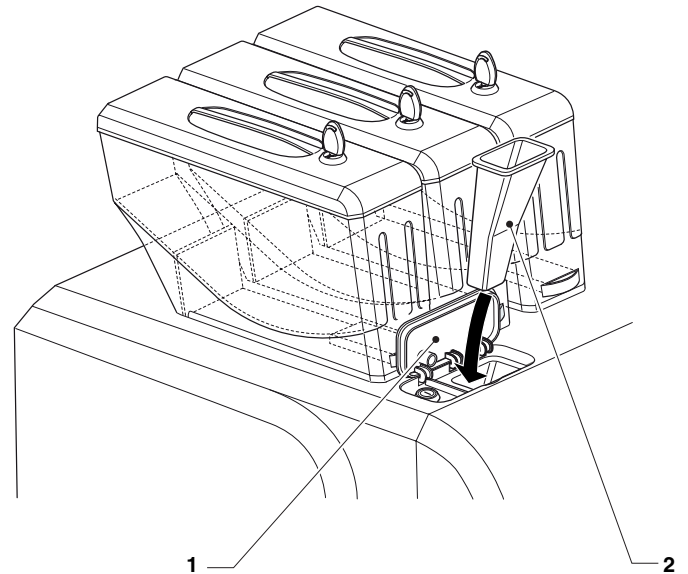

Fig. 16

1. Door for introducing decaffeinated coffee
2. Detergent chute

CLEANING THE TOUCHSCREEN

The touchscreen is touch sensitive; a reduction in sensitivity and/or functional changes may be caused by an accumulation of dirt on the touchscreen.

Use a soft, dry, cloth when cleaning and avoid using abrasive products which contain solvents or alcohol.

Clean the touchscreen using a little pressure.

SERVICE SUSPENSION

If, for any reason, the appliance remains switched off for a long period of time, it is necessary to:

1. Completely empty the containers and wash them carefully with the sterilising products.
2. Completely empty the grinders by dispensing coffee until the empty warning appears.
3. Proceed with the guided wash of the milk circuit (models with a cappuccino maker only), brewing unit and mixers.
4. Close the tap that is positioned upstream of the water hose and completely empty the hydraulic circuit.
5. Disconnect the appliance from the power supply.

Chapter 2 Installation

The installation and the subsequent maintenance operations must be carried out with the **appliance connected to the power supply** and therefore by specialised staff, who are trained to use the appliance and have been informed of the specific risks deriving from such a situation.

The appliance needs to be installed in a dry environment, with a temperature between 2°C and 32°C and cannot be installed in environments where jets of water are used for cleaning (e.g. large kitchens, etc.).

(i) The appliance must be installed in environments where it can be overseen by trained staff.

(i) When the appliance has been installed, the hydraulic circuits and the parts that come into contact with the food products need to be sterilised in order to eliminate any bacteria which could have formed while the machine was in storage.

UNPACKING THE APPLIANCE

After removing the packaging, check the condition of the appliance.

If any doubts should arise, do not use the appliance.

The packaging materials (plastic bags, expanded polystyrene, nails, etc.) must be kept out of the reach of children as they are a potential source of danger.

The packaging materials need to be disposed of in authorised waste disposal centres. Recyclable materials should be given to specialised recycling companies.

Important!

The appliance must be positioned on a levelled surface, so that the maximum inclination does not exceed 2°.

MAIN SWITCH AND SAFETY MEASURES

MAIN SWITCH

The (manual) main switch cuts off the power to the appliance and is positioned behind the solid residue container.

When carrying out normal cleaning and product loading tasks, the appliance does not have to be switched off.

SAFETY MEASURES

The routine cleaning and product loading tasks can be performed safely.

The unit has magnetic sensors which detect:

- The closing of the door
- The presence of the containers
- The presence of the residue containers

In the absence of one of the listed conditions, the appliance is disabled.

This appliance is equipped with a magnet which allows the appliance to operate with the door open.

The magnet must under no circumstances be left inside the appliance, it must be kept by the staff who are trained to use it.

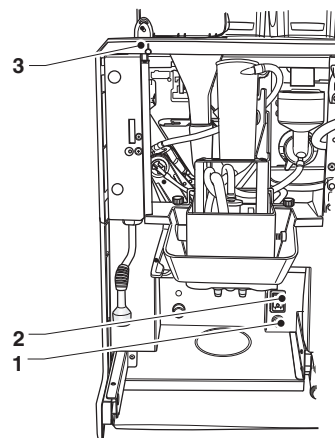

Fig. 17

1. Line fuse
2. Main switch
3. Magnetic door sensor

DISCARDING THE SOLID AND LIQUID RESIDUES

Where possible, you should empty the solid residues into a bucket and connect the liquid residue container to a standpipe.

LIQUID RESIDUES

Connect the liquid residue container to a standpipe using the drain fitting that inserts into the liquid residue container

When this is not possible, it is preferable to use a bucket to collect the residues from the container.

To connect the liquid residue container to the drain fitting, drill the liquid residue container into the drain fitting area.

Make sure that the liquid flows from the container without any obstacles.

SOLID RESIDUES

The solid residues can be emptied directly into a bucket using the solid residue chute supplied as standard, by inserting it into the drain hole.

The solid residue bucket must be housed inside a closed cabinet.

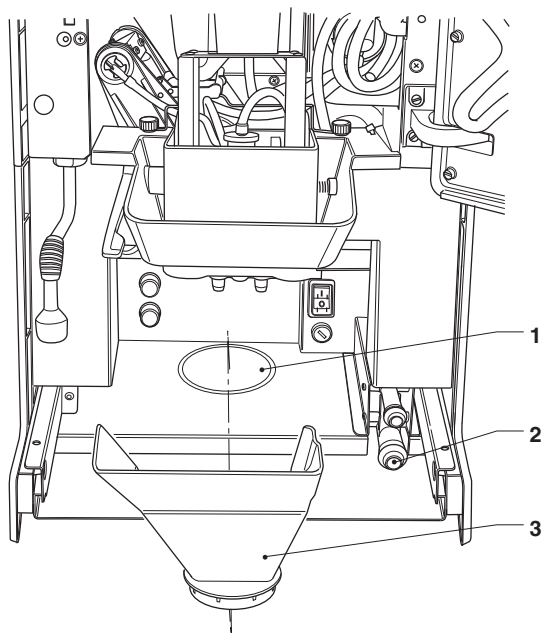

Fig. 18

1. Provision to empty the solid residue
2. Liquid residue drain fitting
3. Solid residue chute

REMOVING THE PANELS

To gain access to the internal components, the panels must be removed.

1. Remove the liquid residue container.
2. Remove the fixing screws of the side panels.
3. Remove the fixing knurls on the side panels.
4. Slide the side panels forward to release them.
5. To remove the rear panel, slide it to the left.

To reassemble the panels, repeat the process in reverse order.

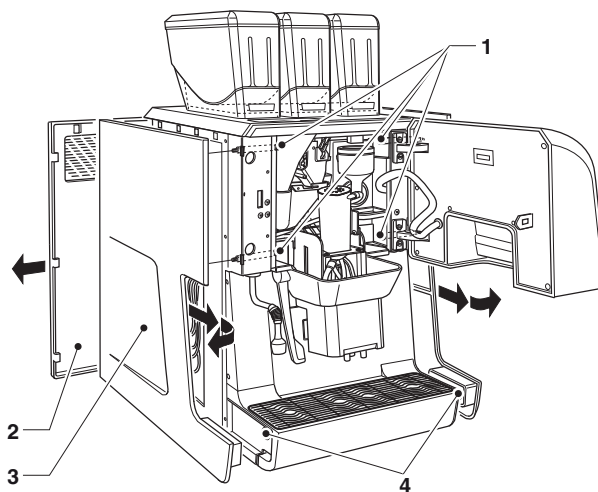

Fig. 19

1. Side panel fixing knurls
2. Rear panel
3. Side panel
4. Side panel fixing screws

WATER SUPPLY

The appliance must use drinking water and take into account the regulations in force where the appliance is installed.

FROM WATER MAINS

The mains water pressure must be between 0.05 and 0.85 MPa (0.5 - 8.5 bar). Run the water from the mains until it is clear and dirt free.

Connect the water mains to the $\frac{3}{4}$ " fitting of the water inlet solenoid valve via a food grade pipe (also available as a kit) that is suitable for withstanding the water mains pressure (minimum internal diameter of 6 mm).

Installing a tap on the water mains outside the appliance and in an accessible position, is recommended.

Only use new seal and pipe sets and do not reuse any existing materials.

OVERFLOW DEVICE

The water inlet solenoid valve is equipped with an overflow device which mechanical stops the water from entering if the solenoid valve or the water level control mechanism malfunction.

To restore normal operation, proceed as follows:

1. Drain the water in the overflow pipe;
2. Shut off the appliance's external water mains tap;
3. Loosen the fitting which secures the solenoid valve feed pipe in order to relieve the residual mains water pressure and tighten it again;
4. Open the tap and supply power to the appliance.

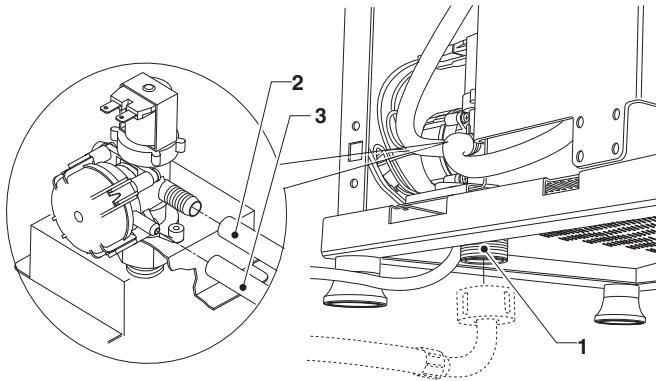

Fig. 20

1. $\frac{3}{4}$ " water inlet fitting
2. Inlet tube
3. Overflow pipe

FROM A TANK

For models without a water inlet solenoid valve only.

Use the specific self-supply kit for the appliance; the kit is supplied with installation and test instructions, which should be scrupulously followed in order to maintain the safety of the appliance.

Place the tank in a clean and protected location (closed cabinet), which can easily be accessed for filling and periodic cleaning.

Important!

Kits which have not been approved by the manufacturer, may not comply with the safety standards, most especially in regards to live parts.

The manufacturer declines any responsibility if non-approved components are used.

The installation and subsequent test operations must be performed by qualified personnel, with specific knowledge of the appliance's operation both from an electrical safety and hygiene point of view.

DESCALER

The appliance is not supplied with a water softener.

In the event that the appliance is connected to a water mains with very hard water, a water softener must be installed.

The water softeners which are available as an accessory, need to be periodically regenerated according to the instructions provided by the manufacturer.

Use water softeners that have a big enough capacity to be effectively used in the appliance.

If the appliance uses a water tank, appropriate filter cartridges can be used.

ELECTRICAL CONNECTION

The appliance requires a single phase voltage of 230-240 V \sim and it is protected by a 15 A fuse.

For the connection, make sure that the nameplate details correspond to those of the mains, and in particular that: the voltage is within the recommended limits for the connection points;

It is mandatory to use a main switch, in accordance with the current installation standards and make sure that it is located in an accessible position. The switch must have the suitable characteristics to withstand the maximum required load and ensure a complete disconnection from the power supply under conditions of overvoltage category III and, therefore, protect the circuit against ground faults, overloads and short circuits.

The switch, the socket and the plug must be placed in an accessible position.

The appliance is to be considered electrically safe only when it has been correctly connected to an efficient earthing system, in accordance with the current safety regulations.

It is important to have this fundamental requirement checked. If in doubt, have the system carefully checked by a qualified professional.

The power supply cable is flexible, has a non-detachable plug and is supplied with the appliance.

The cable connection should be made on the appropriate terminal board on the right side of the appliance, as shown on the wiring diagram.

To connect the cable, the side panel must be removed.

Any connection cable replacements must be solely carried out by qualified personnel and using only the following types of flexible cables: HO5RN-F, HO5VV-F or H07RN-F 3x1-1.5 mm² cross section.

The use of adapters, multiple plugs and/or extension leads is forbidden.

The manufacturer shall not be held responsible for any damage caused due to the non-observance of the above-mentioned precautions.

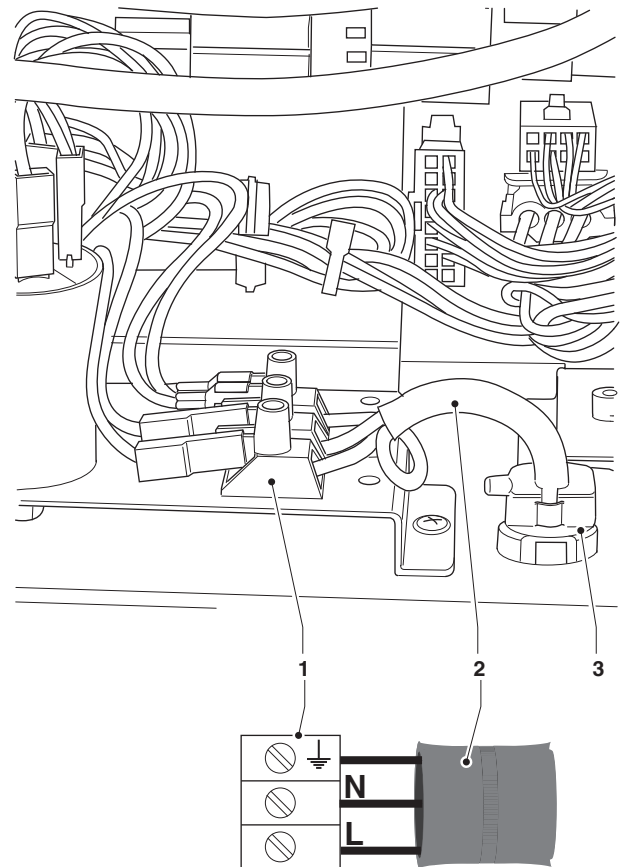

Fig. 21

1. Connection terminal board
2. Electric cable
3. Cable clamp

INITIAL START UP

When the appliance starts up for the first time, a guided sequence will be displayed with some preliminary settings (language, appliance name, etc.).

After the choices have been made, the hydraulic circuit is filled up (installation).

When the appliance starts up, the mains solenoid valve is opened automatically until the hydraulic circuit is filled up.

Note: If there is a lack of water during the installation cycle, the appliance will stop and wait for the water.

If substantial water pockets form in the hydraulic circuit, then the hydraulic circuit must be manually filled.

After the hydraulic circuit is filled, the appliance rotates the brewing unit to correctly position it; the display shows the following in sequence:

- The software version of the appliance and the software version of the touchscreen.
- The heating cycle status of the boilers.

When the heating cycle has finished, the beverages will be available.

FIRST SANITISATION

When the appliance has been installed, a thorough food circuit disinfection needs to be performed (brewing unit, mixers, beverage dispensing ducts, inner tank, milk tank, etc.) to ensure that the dispensed products are hygienic.

Do not under any circumstances use jets of water when cleaning.

The sterilisation is performed using sterilising products.

Wash the mixers by adding a few drops of sanitising solution and fully wash the cappuccino maker and the brewing unit.

Once the sterilisation has been performed, rinse the mixers well to remove any residue from the solution that has been used.

To supply water to the mixers, use the rinse function from the "washes" menu.

Important!

This machine is equipped with an automatic washing programme for the main functional groups.

If the appliance is subject to idle periods (weekends, etc.), even for periods of less than two days, it is good practice to enable the automatic washing functions (before beginning to use the appliance).

OPERATION

BREWER UNIT

After each start-up of the machine, the coffee unit performs a full rotation before performing the normal cycle in order to ensure that the device is positioned in the initial position.

COFFEE DISPENSING CYCLE

If a coffee-based selection is requested, the grinder is activated until the coffee doser chamber is full.

When the doser is full, the coffee dose is released into the infusion chamber which is located vertically inside the coffee unit.

The gear motor engaged on the pinion lets the cranks rotate, which cause the infusion chamber to rotate as well.

The upper piston aligns itself with the infusion chamber and descends inside it. The position where the piston stops for the infusion will depend on the quantity of coffee inside the chamber.

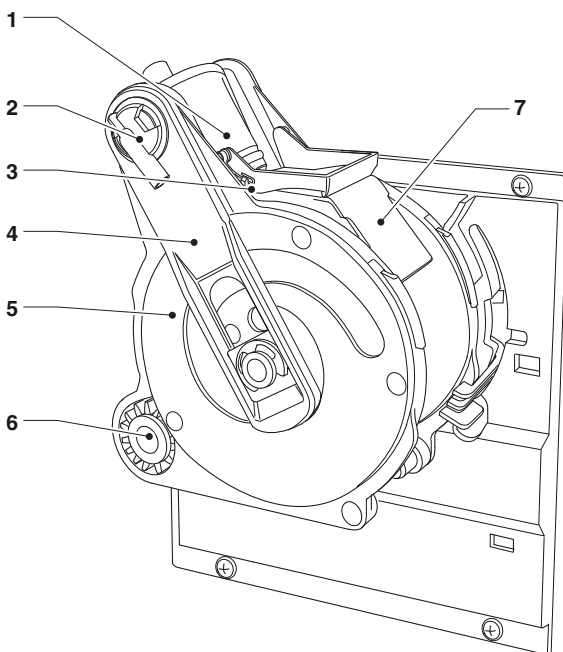

Fig. 22

1. Upper piston
2. Coffee outlet nozzle
3. Scraper
4. Rods
5. Cranks
6. Pinion
7. Exhaust pad slide

At the end of the coffee dispensing phase, the upper piston goes down in order to mechanically squeeze the coffee pod, facilitating the expulsion of excess water through the 3rd route of the dispensing solenoid valve.

At the end of the cycle the gear motor is activated in the opposite direction, lifting the upper piston and rotating the infusion chamber towards the emptying side, on the opposite side of the dispensing side; the lower piston rises.

Once the emptying position is reached, the gear motor inverts its rotation direction again, bringing the infusion chamber back to the idle position.

The scraper holds the coffee pod and lets it fall, while the lower piston returns to the idle position.

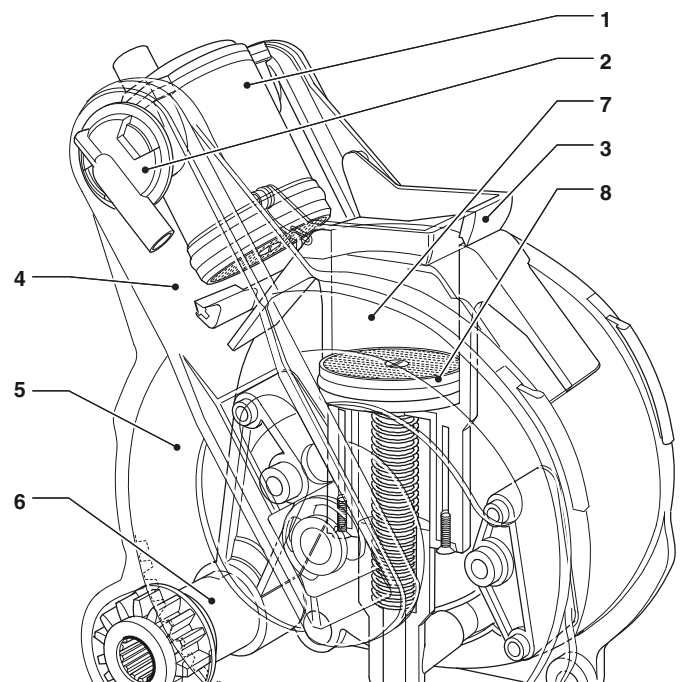

Fig. 23

1. Upper piston
2. Coffee outlet nozzle
3. Scraper
4. Rods
5. Cranks
6. Pinion
7. Infusion chamber
8. Lower piston

VOLUME OF THE INFUSION CHAMBER

The coffee unit can operate with coffee doses between 7 and 13,5 gr.

The upper piston positions itself automatically according to the programmed pressure.

BREWING UNIT ES-FB

Every time the appliance is switched on, the brewing unit carries out a full rotation before performing the normal cycle in order to ensure that the device is in the correct initial position.

The brewing unit can dispense espresso-type beverages (high pressure infusion) and fresh brew beverages (low pressure infusion).

DISPENSING CYCLE

This requires:

- A coffee-based selection that requires grinding; the grinder operates until the coffee doser chamber is full.

When the doser is full, the ground dose is released into the unit's vertical infusion chamber.

or

- A selection that uses pre-ground coffee; the pre-ground product dose is dispensed directly into the brewing unit.

The gearmotor grafted on the pinion, makes the cranks rotate which causes the infusion chamber to rotate 30°.

The upper piston aligns itself with the infusion chamber and descends inside it.

The stop position of the piston for infusion will be:

- For espresso-type selections, this depends on the quantity of ground coffee inside the infusion chamber.

or

- For fresh brew selections, this is fixed and at the highest possible position inside the infusion chamber (low pressure infusion).

According to the desired selection, the drink will be respectively released from the espresso nozzle or the fresh brew nozzle.

When the beverage has been dispensed, the upper piston lowers in order to mechanically compress the coffee pod which causes excess water to be drained via the 3rd route of the dispensing solenoid valve.

At the end of the cycle the gearmotor is activated in the opposite direction, lifting the upper piston and rotating the infusion chamber towards the emptying side, on the opposite side of the dispensing side; the lower piston rises.

Once the emptying position is reached, the gearmotor inverts its rotation direction again, bringing the infusion chamber back to the idle position.

The scraper holds the coffee pod and lets it fall, while the lower piston returns to the idle position.

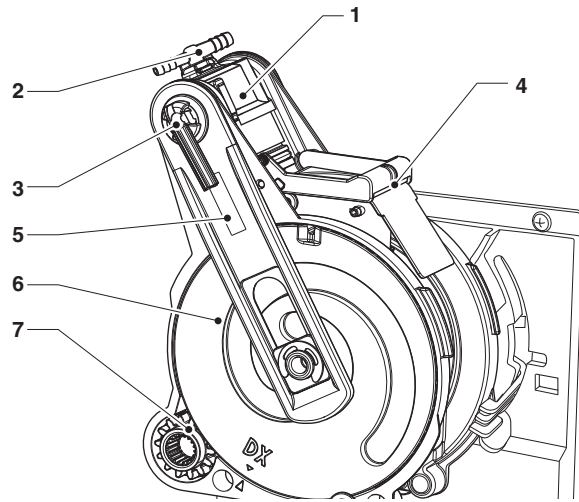

Fig. 24

1. Upper piston
2. Fresh Brew nozzle
3. Espresso nozzle
4. Scraper
5. Connecting rods
6. Cranks
7. Pinion

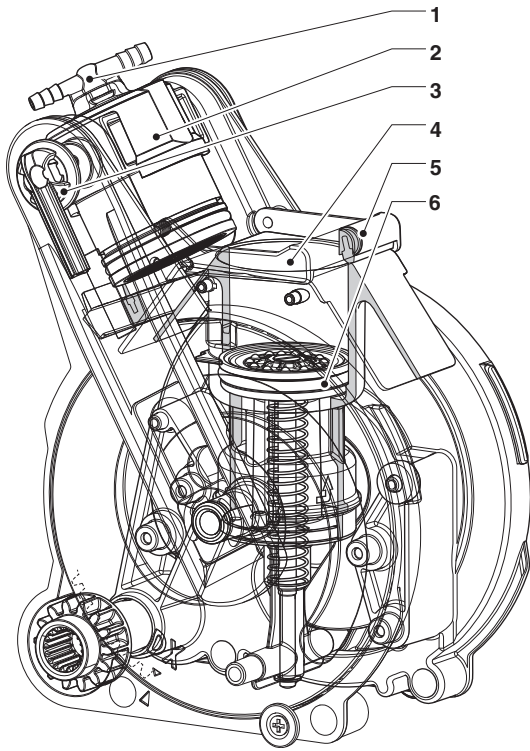

Fig. 25

1. Fresh Brew nozzle
2. Upper piston
3. Espresso nozzle
4. Infusion chamber
5. Scraper
6. Lower piston

VOLUME OF THE INFUSION CHAMBER

The brewing unit can operate with coffee doses between 7.5 and 15 g.

The upper piston automatically positions itself according to the desired selection (espresso or fresh brew).

VARIABLE-DOSE COFFEE DOSER

A coffee-based selection can be composed of two quantities of ground coffee: volumetric and timed; they are released consecutively from the doser.

The dispenser releases the dose of ground coffee when:

- The doser chamber is full (volumetric release).
- When the time which has been set as a percentage is reached, i.e. the volumetric quantity of the grinding time.
If the percentage is set to 0, only one volumetric release is carried out;
If the percentage is set to 100, two volume-dosed releases are carried out (the chamber will also be filled during the second release).

The chamber volume of the variable-dose doser can be adjusted between 5.5 and 8.5 g using the adjustment lever.

The dose adjustment lever can be positioned on one of the 10 reference marks, whilst taking into consideration that:

- Raising the lever increases the dose:
- Lowering the lever decreases the dose:
- Each notch changes the dose by approx. 0.35 g.

Two different doses are managed in each doser: the volumetric dose (for single coffees) and the timed dose (for double coffees).

The coffee unit can accept coffee doses of up to 13.5 g.

- If a completely volumetric dose is opted for (100% time - two releases), the 7 gram adjustment for the doser volume must not be exceeded.

In this case, the dose for single coffee will be composed of 7 g (volume) plus the grams ground in the programmed time (volume grinding other than 100%).

- If you opt for the fully volumetric low dose, the volume will need to be adjusted to the desired dose with the addition of 0% time-ground grams.

In this case, the dose for double coffee will be composed of the volume-dosed grams plus the grams ground in the programmed time (volume grinding other than 0%).

Warning! If the position of the adjustment lever is changed, the percentage value of the added dose will have to be reset.

Ensure the total dose does not exceed 13.5 grams.

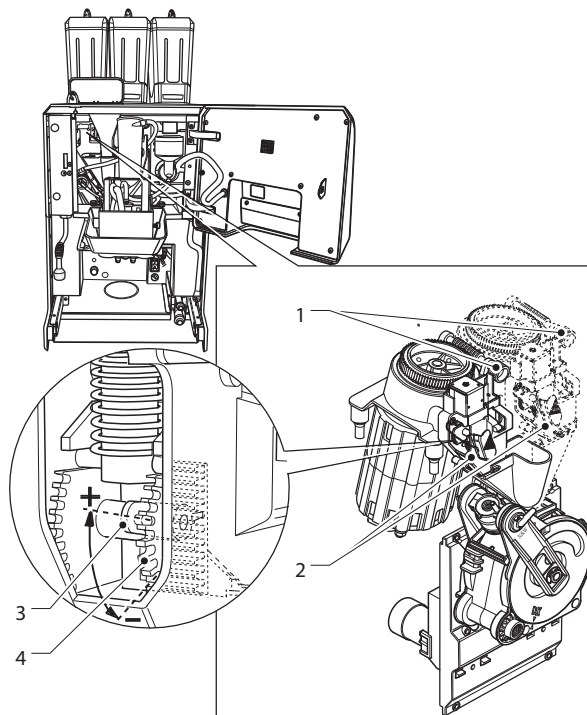

Fig. 26

1. Grinder adjustment knob
2. Doser (1 or 2 depending on the model)
3. Dose adjustment lever
4. Dose adjustment

DISPENSING MILK

For appliances with cappuccino makers, beverages can be dispensed with:

- milk
- hot non-frothed milk
- hot frothed milk

⚠ Danger of scalding! Short spurts of hot water and/or steam may initially come out of the nozzle when dispensing hot milk: do not put your hands in the dispensing area.

MILK

- The milk pump is activated and draws milk from the container.
- The milk goes into the milker nozzle (pushed by the milk pump) and is dispensed into the cup.

HOT NON-FROTHED MILK

- The steam boiler solenoid valve opens and the milk pump is simultaneously activated.
- The milk goes into the milker nozzle (pushed by the milk pump).
- The steam passes through the milker nozzle at the same time as the milk and heats it up.

HOT FROTHED MILK

- The steam boiler solenoid valve and the "air" solenoid valve open and the milk pump is activated; the steam sucks the air as it passes, which is mixed with the milk being pushed by the pump. The "air" solenoid valve is operated intermittently at a determined frequency.
- The milk goes into the milker nozzle (pushed by the milk pump).
- The steam passes through the milker nozzle at the same time as the milk and heats it up.

When the milk dispensing cycle has finished, the milker nozzle is partially washed with a minimal amount of water.

DISPENSING HOT WATER FROM THE SPOUT

For models with a hot water spout only

⚠ Danger of scalding! Short spurts of hot water may come out of the nozzle when the dispensing starts: do not put your hands in the dispensing area.

To dispense hot water from the spout, press the "Hot water" button, or, depending on the model, request the "Hot water" selection.

The appliance dispenses hot water:

- until the set amount is reached.
- Until the "Hot Water" button is pressed again (stop dispensing function).
- Until the "Hot Water" button is released.

CALIBRATION CHECKS AND SETTINGS

STANDARD CALIBRATION

The appliance is supplied with a selection dose table which includes the calibrations and doses that are set as standard.

To obtain the best results for each product used, we recommend the following checks are performed:

- That the coffee pod is slightly compressed and moist.
- The infusion time.
- The grammage of the coffee.
- The temperature of the beverage at the nozzle.
- The water dose.

The grammage of the product, the amount of water and the temperatures are controlled directly by the control electronics.

To change these, follow the procedures described below.

COFFEE DOSE

The maximum coffee dose that can be used by the brewing unit is 13.5 g.

Depending on the dispensing type (single or double), the volume of the doser chamber must be adjusted.

By difference, and depending on the desired dose, the percentage of the grinding time to be programmed for the second quantity of coffee must be determined.

WATER DOSE

The type of selection determines the amount of water to be dispensed.

ADJUSTING THE COFFEE GRAMMAGE

The dose adjustment lever can be positioned on one of the 10 reference marks, whilst taking into consideration that:

- Raising the lever increases the dose;
- Lowering the lever decreases the dose;
- Each notch changes the dose by approx. 0.35 g.

To collect the dose, simply remove the coffee unit and use the appropriate "test" menu function in "technical" mode (see relevant paragraph).

Important!

The dose that can be used is approximately between 7 and 13.5 g; vary the degree of grinding to slightly change the dose.

COFFEE GRIND ADJUSTMENT

To vary the degree of grinding (to make it finer or coarser), turn the grinder's adjustment knob:

- For a coarser grind, turn the knob anti-clockwise (away from the grinders).
- For a finer grind, turn the knob clockwise (towards the grinders).

ⓘ The finer the grinding degree, the longer the coffee dispensing time will be and vice versa.

It is good practice to change the degree of grinding when the coffee grinder motor is enabled.

Note: after the degree of grinding has been changed, at least 2 selections need to be performed to safely check the new ground coffee grain size.

CALIBRATING THE MILK

For models with a cappuccino maker only

AMOUNT OF MILK

The amount of milk required for each selection can be programmed from the menu.

TEMPERATURE

The temperature of the milk varies according to the milk flow.

After significant variations, the dispensed milk dose must be checked.

FROTH

It is possible to enable and disable the air and milk emulsion from the programming menu.

STEAM BOILER(S) TEMPERATURE

The temperature of the steam boiler(s) is controlled by the software and can be directly adjusted from the menu.

TOUCHSCREEN

Only use fingers to interact with the touchscreen; do not use sharp objects.

If the touchscreen is not used and displays the same screen for a long period of time, afterimages or movements may appear: turn off the touchscreen (energy saving) or set a screensaver.

Using high-quality content will affect the general performance.

TOUCH

Touch icons, features and objects to activate or open context menus.



Fig. 27

MOVE AND DRAG

To move and drag icons and objects, touch and drag them to a new location.

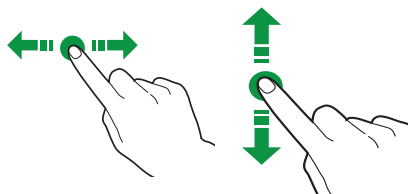

Fig. 28

SCROLL

Slide your finger to the right, left, up or down on the touchscreen to scroll through the values, screens and functions.

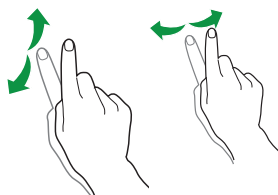

Fig. 29

OPERATION IN NORMAL USER STATUS

The layout and arrangement of the icons/screens in this manual is indicative only and may vary from those displayed on the appliance, depending on the settings (layouts, themes, and/or icons).

When operating normally, the appliance displays the screen with the available selections.

In the event that an anomaly is detected by the control electronics, a message will be displayed, indicating the type of fault / error.

Some selections may be disabled when certain types of faults occur (e.g. product containers empty, etc.).

With some of the personalised settings (i.e. moving the beverages to a different place) some selections may not be displayed: simply scroll through the screen.

DISPENSING A BEVERAGE

Select a beverage.

The screen with the beverage customisations can be displayed.

Whilst the beverage is being prepared, the beverage's status is shown; alternatively, entertainment content can be shown instead (e.g. a video).

It is possible to stop a beverage's preparation if it has been enabled from the menu.

APPLIANCE STATUS

The appliance status can be displayed (e.g. faults, etc.) via the status panel.

The status panel:

- Displays fault/ error notifications;
- Displays the nutritional information of the selections;
- Allows the language of the displayed messages to be changed;
- Displays the filling level of the containers;
- Displays the available wash functions;
- Provides access to the programming menu.

VIEWING THE STATUS PANEL

Tap the top centre of the touchscreen.

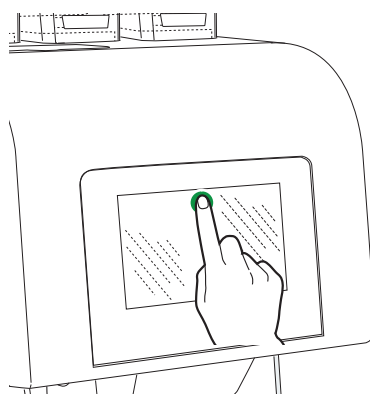

Fig. 30

CLOSING THE STATUS PANEL

Drag the bottom of the status panel upwards.

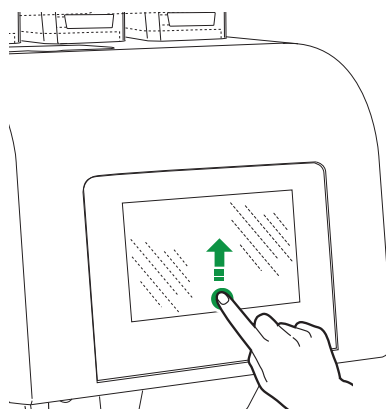

Fig. 31

notes regarding Programming

The electronic control unit of the appliance allows many functions to be used.

A brief explanation of these main functions is provided below. They are useful for better managing the appliance's operation but are not necessarily in the same order as they are displayed in the menu.

Some functions that are specific to certain functional groups may be described; functional groups that differ depending on the model.

The layout of the icons/ screens in this manual is indicative only and may vary from those displayed on the appliance, depending on the settings (layouts, themes, and/or icons).

ACCESSING THE PROGRAMMING MENUS

To access the programming menu:

- With the door closed, tap **SETTINGS** 
or

- Open the door of the appliance.

Depending on the settings, a password may be required before being provided access to the programming menus.

Enter the password to access the enabled menus.

The (default) passwords are:

- Technician (4444)
- Distributor (3333)
- Loader (2222)
- User (1111)

MENU

Touch **MENU**  to view the appliance menu functions.

The available functions for the current user profile will be displayed.

Some functions and/or parameters may not be displayed: simply scroll through the screen.

EXIT

Touch **EXIT**  to come out of the programming menu.

The selections page will be displayed.



FAVOURITES

FAVOURITES  are shortcuts to frequently used functions.

After a function has been added to **FAVOURITES**, simply view the **FAVOURITES** and touch the function for quick access.



Touch **FAVOURITES**  to access the frequently used and saved functions as **FAVOURITES**.

ADDING A FUNCTION TO "FAVOURITES"

Via the function screen, touch ; it will change colour ( is activated).

REMOVE A FUNCTION FROM "FAVOURITES":

- From the favourites screen, tap the function to be removed in order to access that function.

- Tap : it will change colour ( is disabled).

KEYPAD

Tap  to display the keypad.

INFORMATION AREA

Displays information regarding the appliance (software version, etc.).

MESSAGE AREA

Displays messages of an informative nature, e.g. statistics on the most requested selections, etc.

FAULT AREA

Displays the faults found on the appliance.

MAINTENANCE INFORMATION AREA

Displays information regarding the maintenance deadlines.

MAINTENANCE NOTIFICATION sets the current date/ time as the last date of maintenance.

ENTERING VALUES

The values in the programming menu can be entered/ modified as follows:

KEYBOARD

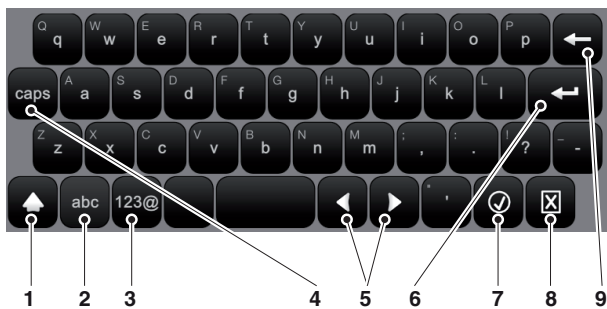

Fig. 32

1. Uppercase (shift)
2. Key to switch the "number/ symbol" keyboard to the "letter" keyboard
3. Key to switch the "letter" keyboard to the "number/ symbol" keyboard
4. Caps Lock
5. Shifts the cursor in the text
6. New line (text over two lines)
7. Confirm
8. Cancel
9. Clear (back space)

KEYPAD

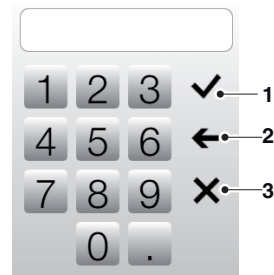

Fig. 33

1. Confirm
2. Clear (back space)
3. Closes the keyboard

CHECKBOX

Tap the checkbox to enable / disable the option.



Fig. 34

DROP-DOWN LISTS

Tap to open the drop-down list and select the value.

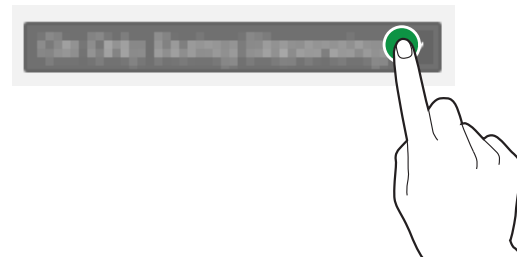

Fig. 35

VALUE PICKERS

Scroll and select the desired value.

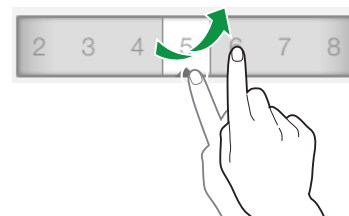

Fig. 36

DAILY ACTIONS

Groups together all of the functions that are used on a daily or more frequent basis (washes, resetting the residue counters, etc.)

CLEANING AND WASHES

Automatic washing and rinsing functions of the appliance's functional units (infuser, mixer, etc.).

Select the components that require washing.

Some washes might require parameters to be set (e.g. the amount of water to use, etc.).

FILLING UP

If the container level check is deactivated, the function is not available.

The function allows the pre-alarms or the container empty warning to be managed correctly (if enabled).

After each product has been loaded, the quantity of loaded product must be indicated.

EMPTYING THE SOLID RESIDUE CONTAINER

Resets the counter which handles the "residue full" warning when the solid residue container is full.

In order to correctly manage the warnings, the counter must be reset each time the solid residue container is emptied.

MANAGING MONEY

Enabled only for models with payment systems.

With this function, it is possible to:

- Empty the coins from the coin box change-giver tubes.
- Insert coins into the coin box tubes to activate the change-giver function.
- Check the total amount of money in the coin box.

SELECTION SETTINGS

DISPLAY LAYOUT

Select the layout of the selections from the default ones which are displayed in normal user mode.

To change the order of the selections, drag the selection icon to the new position.

To make a selection available or unavailable when the appliance is in normal user mode, drag the selection icon from the available selections and vice versa.

DISPLAY LAYOUT OF THE SELECTION CATEGORIES

With the management by categories, the selections can be grouped by type.

For each category, a selection layout can be chosen.

To change the order of the selections, drag the selection icon to the new position.





To make a selection available or unavailable in a category, drag the selection icon from the available selections and vice versa.

SELECTION CATEGORIES

Allows the selection categories to be created, modified or deleted.

The selection categories are displayed during normal operation and they allow the selections to be grouped by their beverage type (e.g. "milk-based beverages").

The function allows:





- A new category to be created ;
- A category to be duplicated  and modified ;
- A category to be deleted ;
- The available categories to be enabled/disabled.

CREATING OR MODIFYING A CATEGORY

The name, description and icon of a category can be assigned or modified.

BEVERAGES

From the screen, it is possible to:

- Create new drinks and associate a recipe .
The software checks that there is compatibility between the recipe and appliance configuration (layout).
If  is displayed it means that an incompatibility has been detected.
- Delete a beverage .
- Duplicate  and customise  a beverage.





CREATING OR MODIFYING A BEVERAGE

It is possible to:

- Assign/ modify the name of beverages displayed during normal operation.
- Select which recipe to use when preparing the beverage.
By default, the appliance uses recipes for single drinks; for double selections (X2), recipes with adequate doses need to be created.
The software checks that there is compatibility between the recipe and appliance configuration (layout).
If  is displayed it means that an incompatibility has been detected.
- To change the image associated with the beverage, touch the image to choose a new image.
- Enable the option to prematurely stop a selection (“stop dispensing” function).
- Associate a multimedia content *playlist* to be displayed whilst dispensing.
- Dispense a test beverage.

RECIPES



It is possible to:

- Create a new recipe .
The newly created recipe is saved in the “not available” category.
Then, associate the recipe to the beverage.
The software checks that there is compatibility between the recipe and appliance configuration (layout).
If  is displayed, it means that an incompatibility has been detected
- Delete a recipe .
- Duplicate  and customise  a recipe.

CREATING A NEW RECIPE

The guided procedure allows a new recipe to be created.

A screen is displayed where:

- A name can be assigned to the new recipe.
- Set a wait time (in seconds) for the “Take beverage” message to appear when the beverage has been dispensed.
The wait time allows the hoses to be emptied and drip into the cup.
- Tap  and then “Add preparation” to add the products which make up the recipe (e.g. coffee, chocolate, etc.).
The parameter screens vary according to the added product (espresso coffee, fresh brew coffee, instant powders, etc.).
- To customise the beverage, tap  and then “Add customisation”.
For every customisation option, the various parameters can be set.
- Save the settings and return to the main screen.

From the main screen, “Test recipe” allows a test selection to be dispensed in order to check the created recipe.

After the test selection, the recipe can be modified.

MODIFYING A RECIPE

From the recipe screen, it is possible to:

- Change the name of a recipe.
- Set a wait time (in seconds) for the “Take beverage” message to appear when the beverage has been dispensed. The wait time allows the hoses to be emptied and drip into the cup.

Other ingredients and/or customisations can be added to the recipe.

From the recipe screen, tap  to add other ingredients and/or customisations.

To change the settings of individual ingredients (e.g. the amount of water, powder, etc.), touch the ingredient bar to open the context menu.

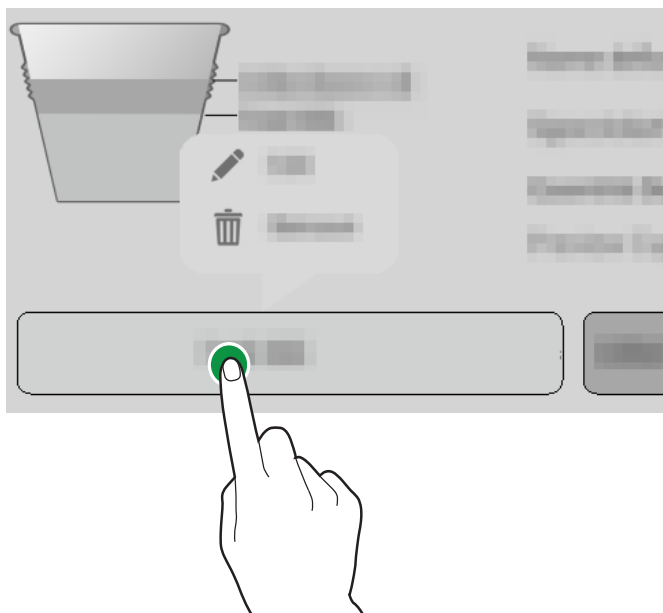



Fig. 37

- Tap EDIT  to change the parameters.
- Tap REMOVE  to delete the ingredient.

To move an ingredient before or after another ingredient, simply drag the bar of the ingredient.

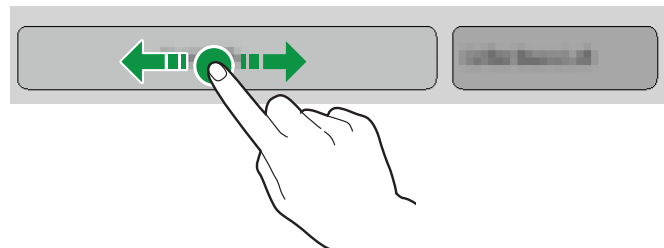

Fig. 38

After changing the parameters, save the settings and return to the main screen. From the main screen, “Test recipe” allows a test selection to be dispensed in order to check the modified recipe.

BASIC PARAMETERS

It is possible to:

- Set the name of the ingredient.
- Set the doses (water and powder).
- Dispense a test beverage.

Customisations can be added to the recipe (e.g. chocolate intensity, sugar variation, total amount of water, etc.).

For each customisation, specific parameters must be set.

For appliances with a payment system, the price changes of a selection can be set.

The timed ground dose is indicated as a percentage, compared to the time taken to volumetrically grind the coffee.

ADVANCED ESPRESSO PARAMETERS

START DELAY

Sets an ingredient time delay; the delay is useful if a recipe which consists of multiple ingredients is created.

For example, when creating the "Espresso with milk" recipe, a time delay can be set between when the coffee and the milk is dispensed.

It can help the beverage be presented better.

POD SQUEEZING

The squeezing is carried out by the upper piston which, by mechanically compressing the pod, favours the expulsion of the water from the pod before it is discarded into the solid waste container.

- ON: the pod squeezing is enabled.
- OFF: the pod is not squeezed.

SQUEEZE DOWN FORCE

Sets the squeezing force exerted on the pod by the piston when the coffee has finished being dispensed.

SQUEEZE REST FORCE

Sets the safety value of the squeezing force on the pod.

⚠ This value must be greater or equal to the "squeeze down force".

PRE-INFUSION DOSE

Sets the amount of water (in ml) to be used during the pre-infusion.

PRE-INFUSION TIME

Sets the pre-infusion time before the actual infusion occurs.

CURRENT PROFILE

Sets 3 pressure profiles for the espresso infusion:

- High
- Medium
- Low

When using the low setting, the low pressure infusion parameters are displayed (see the fresh brew parameters).

TACHO VALUE LIMIT

Sets the height of the upper piston in the chamber during the low pressure infusion (fresh brew).

The default value is 430.

⚠ If a value lower than the default value is set, this can lead to hot water escaping from the brewing unit.

PRE-INFUSION DOSE

Sets the amount of water to be used during the pre-infusion.

PRE-INFUSION TIME

Sets the pre-infusion time before the actual infusion occurs.

CURRENT PROFILE

Sets 3 pressure profiles for the espresso infusion:

- High
- Medium
- Low

When using the low setting, the low pressure infusion parameters are displayed (see the fresh brew parameters).

ADVANCED INSTANT PARAMETERS

START DELAY

Sets an ingredient time delay; the delay is useful if a recipe which consists of multiple ingredients is created.

For example, when creating the "Hot chocolate with milk" recipe, a time delay can be set between when the powder and the milk is dispensed.

It can help the beverage be presented better.

MIXER DELAY

Sets a start delay time for the mixer, compared to when the water is dispensed.

ABSOLUTE MIXER MIX TIME

The mixing duration can be set independently from the pump/ valve operation time. The mixing duration is set in milliseconds and calculated from the moment the pump/ solenoid valve is activated.

RELATIVE MIXER TIME

The mixing duration can be set differently, by stopping it before or after the pump/ solenoid valve stops.

The mixing duration is set in milliseconds and calculated from the moment the pump/ valve is activated.

MIXING SPEED (LOW / MEDIUM / HIGH)

The mixing speed can be defined according to the desired presentation of the product.

WATER QUEUE

Extends the amount of water dispensed into the mixer after the mixing stage has finished, in order to adequately rinse the mixer.

Set the desired amount of water.

POWDER SPEED

Sets the working speed of the motor-doser to define its flow rate.

POWDER DELAY

An instant powder time delay can be set so that it starts after the water has been dispensed into the mixer (activation of the pump/ solenoid valve).

STEP

The instant powder is dispensed at regular intervals simultaneously with the water.

Set how many intervals are required to dispense instant powder whilst the water is being dispensed.

Set the intervals (steps) according to the powder used, in order to obtain a high-quality and well-presented beverage.

DECAFFEINATED COFFEE CYCLE

The instant powder is dispensed before the water to improve the presentation of the beverage.

Enabling this option is recommended for instant coffee.

ADVANCED MILK PARAMETERS

START DELAY

Set a time delay for when to dispense the milk, after the previous ingredient.

It can help the beverage be presented better.

MILK SPEED

Sets the milk pump flow rate in cm³/s.

TRIGGER TIME

When the dispensing starts, the milk pump is activated at maximum speed for a set time; this makes up for any pockets in the milk circuit.

After this time, the pump speed is automatically adjusted according to the set flow rate.

ENABLING STEAM

It is possible to enable/ disable the steam dispensing function whilst the milk is being dispensed.

The steam heats the milk in the milker nozzle.

If the function has been disabled, the milk is not heated.

STEAM DELAY

Sets the time delay of the steam solenoid valve opening so that it opens after the milk pump has been activated.

STEAM QUEUE

Extends how long the steam is dispensed for after the milk pump has been disabled.

Set when to disable the steam solenoid valve after the milk pump has been disabled.

ENABLING AIR

The air solenoid valve can be enabled/ disabled whilst milk-based beverages are being prepared.

For selections which require non-frothed milk (e.g. hot milk), keep the solenoid valve disabled.

AIR DELAY

Sets the time delay of the air solenoid valve so that it starts after the milk pump has been activated.

AIR QUEUE

The air solenoid valve remains active (for a set time) after the milk pump has been disabled.

NOZZLE WASH WAITING TIME

Once the selection has been dispensed, a small amount of water can be dispensed into the milker nozzle to partially clean it.

Set when (after the selection has ended) to dispense a small amount of water.

The amount of water used to partially wash the nozzle, will finish in the cup.

NOZZLE WASH TIME

Set how long to supply water for, in order to partially wash the milker nozzle.

The amount of water used to partially wash the nozzle, will finish in the cup.

An excessive time affects the amount and quality of the beverage.

⚠ The milker nozzle wash does not replace the need to disassemble the milker nozzle for regular sanitisation.





TIME TO EMPTY THE MILK CIRCUIT

When the milk has finished being dispensed, the milk hose can be set to be emptied (rotate in the opposite direction to the milk pump).

Set the time to 0 to disable this feature.

INGREDIENTS

From the screen, it is possible to:

- Create new ingredients to be associated to the containers .
- Assign a name to the ingredient.
- Enter the nutritional information and an image.
- Delete an ingredient .
- Duplicate  and customise  an ingredient.

CONTAINERS

According to the machine layout, how the product containers have been arranged can be shown.

Choose a container in order to:

- Assign a name to the container.
- Associate an ingredient to the container (chocolate, espresso, 2 espressos, etc.).
- Set the maximum capacity of the container in order to manage the "product running out" check.
- Change the colour associated with the container.

LAYOUT

It is the mechanical layout of the configuration used by the appliance.

It shows the arrangement of the containers and main functional groups.

The appliance's new mechanical settings can be indicated to the software.

Make sure your settings match the actual configuration of the appliance.

The appliance adjusts the operating cycles of the functional units according to the choices that have been made.

Settings that do not comply with the actual configuration can be dangerous and cause damage to the appliance.

MACHINE SETTINGS

CONFIGURATION

SELECT CONFIGURATION

It lets the appliance's group and individual configurations to be managed.

A group of configurations contains multiple individual configurations (layout).

Groups of configurations and individual configurations can be deleted and duplicated.

When using a new configuration, you can decide whether to reset the statistical data, calibrations, and maintenance counters or not.

(i) Before uploading the configuration of another appliance (cloning), make sure that the two appliances' settings are compatible.

BACKUP

Allows the machine settings to be saved as a backup file.

RESTORE

Allows the backed-up machine settings to be restored.

The appliance can be restored to its:

- Factory settings;
- Previously-saved custom settings.

After having restored the settings from the configuration file, enter the configuration menu and "Select configuration".

IMPORTING FROM A USB

Allows the new machine settings to be imported from a configuration file that has been saved onto a USB stick.

(i) The import function can be used to clone the settings of another appliance; make sure that the two appliances' settings are compatible.

EXPORTING USING A USB

Allows the machine settings to be exported into a configuration file on a USB stick.

(i) The export function can be used to clone current settings onto another appliance; make sure that the two appliances' settings are compatible.

MODIFYING INTERFACE STRINGS

The names of the beverages, recipes, containers and nutritional information, which are displayed on the screens, can be changed in the available languages.

The programming menu strings cannot be changed.

CUSTOMISING THE INTERFACE

EDIT

Allows some user interface graphics to be set, such as backgrounds, text size, colours, etc.

CUSTOM GRAPHICS

Allows which custom graphics file to be applied to the user interface to be chosen.

The files uploaded via the "import" function will be displayed.

IMPORT

Allows the custom graphics files on the USB stick to be browsed through and selected, in order to be imported onto the appliance.

EXPORT

Allows the custom graphics to be saved onto a USB stick.

GENERAL DISPLAY SETTINGS

Enables / disables the display of:

- Multimedia content which is normally available when dispensing.
- Set the touchscreen's brightness; set it at 100 for maximum brightness.
- Displays the number of dispensing cycles completed since the appliance has been switched on.
- The price of the selections when operating normally (for models with a payment system).
- Time and date.
- Boiler temperature.
- Screensaver; when enabled, you can enter after how long to activate the screensaver.
Select whether to display a screensaver or a *playlist*.

PLAYLIST

Allows *playlists* with entertainment content to be created and managed.

A *playlist* contains videos and/or image sequences that are played whilst the selection is being dispensed.



 If a playlist only contains images, you can indicate after how long to show the next image.

 adds videos or images to the *playlist*.

 copies the *playlist*.

 deletes the *playlist*.

A name must be assigned to a new *playlist*.

The *playlist* contents can be played in the following modes: random  or cyclic .

INPUT SENSOR SETTINGS

The functional unit allows the operation of some of the appliance's sensors to be set.

CONTAINER LEVEL

Enables/ disables the container level control.

The container level is calculated. The amount of product used in the recipe is subtracted from the container's capacity.

In order to correctly manage the level, indicate (every time the products are loaded) the amount of product that has been loaded into the container.

The various containers with their filling levels and adjustable parameters are displayed:

- Calculated amount: enables the counter which manages the "product running out" warnings.
- Total capacity: set the maximum container capacity in grams.
- Threshold value: set the warning threshold in grams.

The level of the containers can be checked from the appliance's status window.

SOLID RESIDUES

Enables/ disables the solid residue counter which manages the "residue container full" warning.

- Set the maximum capacity of the solid residue container; the capacity is expressed in number of selections.
- Set the warning threshold (expressed in number of selections).

The level of the residue containers can be checked from the appliance's status window.

CALIBRATIONS

FLOW METER CALIBRATION

The flow meter calibration allows the correct amount of water to be obtained for the recipes.

To calibrate the flow meter, proceed as follows:

1. Dispense and draw the preset amount of water.
2. Measure the amount of water dispensed (in cc).
3. Enter the measured value.

A calibration adjustment value (positive or negative) may need to be used for beverages dispensed by the brewing unit.

CALIBRATING THE GRINDER

The calibration allows the grinder working speed to be adjusted, according to the grams to be ground.

To calibrate, proceed as follows:

1. Start the calibration procedure: a dose of coffee beans will be ground and released.
2. Weigh the ground coffee.
3. Enter the value of the measured weight.

CALIBRATING THE MOTOR-DOSER

The calibration of instant products and pre-ground coffee in the motor-dosers allows the motor-doser operating speed to be adjusted and the flow rate to be defined in g/sec.

To calibrate, proceed as follows:

1. Dispense the powder at the lowest speed.
2. Weigh the dispensed instant powder.
3. Enter the value of the measured weight.
4. Dispense the powder at the fastest speed.
5. Weigh the dispensed instant powder.
6. Enter the value of the measured weight.

CALIBRATING THE PUMPS/ SOLENOID VALVES

The calibration allows the flow capacity to be adjusted in cc/sec.

To calibrate, proceed as follows:

1. Dispense the water at the minimum flow rate.
2. Measure and enter the amount of dispensed water.
3. Dispense the water at the maximum flow rate.
4. Measure and enter the amount of dispensed water.

CALIBRATING COLD WATER

For models that dispense cold water only. The cold water is calibrated in order to obtain the correct quantity of water in the recipes.

To calibrate, proceed as follows:

1. Dispense a pre-set amount of water.
2. Then, measure the amount of water dispensed (in ml).
3. Enter the measured value.

CALIBRATING MILK

For models with a cappuccino maker only. The milk is calibrated in order to obtain the correct amount of water in the recipes.

To calibrate, proceed as follows:

1. Dispense milk at the minimum flow rate.
2. Measure and enter the amount of dispensed milk.
3. Dispense milk at the maximum flow rate.
4. Measure and enter the amount of dispensed milk.

OUTPUT SETTINGS

BREWING UNIT

- No coffee: a sensor detects the rotation of the grinder when it is grinding; if a block (e.g. foreign bodies) or excessive speed (grinder empty) occurs, the control blocks the selections which use the grinder.
- Pregrinding: enables/ disables the coffee grinder for the next selection. Pregrinding reduces the preparation time of the next selection containing ground coffee. Pregrinding affects the aroma of the next selection containing ground coffee.
- Allows the position of the brewing unit's infusion chamber to be set.
Set the infusion chamber's position to allow the coffee powder to be arranged more evenly in the infusion chamber.

FAN PARAMETERS

Enables/ disables the operation of the appliance's fans.

STEAM SUCTION

- ON: the fan is always active.
- OFF: the fan is active whilst the beverage is being prepared.
The fan stays on until the dispensing is complete and for the time that has been set.

LIGHTING

Allows the appliance's lighting parameters to be set.

"USE DECAFFEINATED COFFEE" OPTION

The "use decaffeinated coffee" option can be enabled for selections which use coffee (beans and/or pre-ground).

MILK PARAMETERS

Allows the amount of milk to be drawn to be set, in order to fill the milk circuit before dispensing a milk-based selection.

This value helps compensate for the distance between the milk tank and the appliance and/or for pockets in the milk circuit. If the milk tank is very close to the appliance, set the value to 0.

Dispense some milk-based beverages to check that the entered value is adequate for obtaining the correct beverage quantity.

MAINTENANCE

PROGRAMMING AUTOMATIC WASHES/ RINSES

The appliance's automatic wash and/or rinse cycle programmes can be enabled/ disabled.

Programme the type of wash and/or rinse to be performed on the day and time that has been set.

It is possible to add and remove automatic wash/ rinse cycles.

⚠ The automatic washes /rinses use hot water. Do not place your hands in the dispensing area: there is a danger of burns.

During the washes and rinses, a message appears showing the progress of the operation.

NEXT MAINTENANCE

Enable and set the number of days and/or the number of dispenses.

When one of the values that has set is reached, the appliance will display a "perform maintenance" message.

MAINTENANCE NOTIFICATION

Reset the counter which manages the maintenance alerts.

ⓘ In order to correctly manage the notifications, only reset the counter to zero after all of the maintenance work has been carried out.

WASH MESSAGES

Set the intervals (number of hours and/or selections) for each type of wash/ rinse.

When the set values have been reached, the appliance will display a wash/ rinse message.

Each wash/ rinse can be made compulsory: the appliance or some functional units will not work until a wash/ rinse has been performed.

NEXT WASHES

Displays when the next wash/ rinse will be required for each type of wash/ rinse.

GENERAL SETTINGS

TANK

The appliance can be supplied by mains (OFF) or a tank (ON).

ENABLING THE DISPENSING COMPLETE SIGNAL

Enables/ disables a beep when the appliance has finished dispensing.

ENABLING THE PAYMENT SYSTEM

Enables/ disables the appliance's payment system.

Enable the payment system to activate all its features (price settings, etc.).

ACCESSING THE MENUS WITH THE DOOR CLOSED

Enables/ disables access to the programming menus with the door closed.

POWER SUPPLY

Allows the type of electric connection or voltage supply used for powering the appliance to be set.

Check the type of electrical connection used before making your choice.

The setting allows all the electrical components to be correctly managed and optimises the appliance's operating cycles.

BOILER PARAMETERS

Sets the operating parameters of the boiler(s).

- Temperature: sets the operating temperature of the boiler.

- Minimum temperature for dispensing beverages: sets the minimum temperature for making beverages available.

If the boiler temperature is lower than the temperature that has been set, a "low temperature" error message will be displayed.

With the "Temperature threshold" and "Minutes" parameters, the boiler's temperature maintenance cycle can be set.

For example, if no beverages are dispensed during the set minutes, the temperature of the water in the boiler is increased by the degrees set in the "Temperature threshold".

MODELS WITH A CAPPUCCINO MAKER

- Steam boiler pressure: set the steam boiler pressure value.

For each pressure value, the appliance displays the corresponding temperature.

- Minimum steam boiler pressure: sets the minimum pressure for making beverages which require steam available.

If the boiler pressure is lower than the pressure that has been set, a "low pressure" error message will be displayed.

For each pressure value, the appliance displays the corresponding temperature.

MIXER ANTI-LOCK

Sets how long after the last instant selection to briefly activate the mixers (anti-lock function).

The function is useful if instant powder residues remain in the mixers.

MACHINE INFORMATION

FAULTS

The appliance has a number of sensors which keep the various functional groups under control.

When an anomaly is detected, the appliance displays the type of fault and the appliance (or part of it) is put out of service.

Detected faults are stored in specific counters.

FAULT HISTORY

This function makes it possible to view a list of the fault history; the fault history contains the name of the fault with the date and time.

With this function, the list of reported faults can be reset to zero.

EVENT HISTORY

This function allows the events reported by the appliance to be viewed and filtered.

With this function, the list of reported events can be reset to zero.

FAULTS

Displays the faults found on the appliance.

If there are no faults, the list will be empty.

DOSER 1...9 FAULT

If the current absorption of a motor-doser does not fall within the range of default values, all the selections which involve that motor-doser will be disabled.

MIXER 1...6 FAULT

If the current absorption of a motor mixer does not fall within the range of default values, all the selections which involve that mixer will be disabled.

SOLENOID VALVE 1...7 FAULT

If the current absorption of a solenoid valve does not fall within the range of set values, all the selections which involve the solenoid valve will be disabled.

SHORT CIRCUIT MOSFET

If a control device for the DC motors on the activation board (mosfet) remains active, the machine will signal a fault.

SHORT CIRCUIT

If the software detects a short circuit in one of the DC motors connected to the activation board, this fault will be displayed. It is possible that a fault will also be detected on one of the DC motors at the same time.

FLOW METER

Failure to count the flow meters within a maximum time.

AIR-BREAK WATER LEAK

The Air-break microswitch signals a lack of water without any water being dispensed.

The water inlet solenoid valve opens and the internal power supply pump is activated (tries to fill the air-break).

Check that water is not leaking from the appliance's hydraulic circuit (disconnected pipes, etc.)

AIR-BREAK MICROSWITCH

The Air-break microswitch never signals a lack of water after water has been dispensed.

TIME OUT FOR FILLING THE AIR-BREAK

The air-break microswitch does not signal that the water level has been reached in the air-break if this occurs during the allotted time when filling.

TIME OUT FOR FILLING THE BOILER

The boiler was not filled within the allotted time.

COFFEE UNIT -MICROSWITCH UNIT FAULT-

When handling the brewing unit, the control microswitch was not activated within a certain time limit.

It is possible that this fault is combined with another coffee unit positioning fault.

COFFEE UNIT -UNIT START FAULT-

The microswitch indicates the permanence at the rest point.

COFFEE UNIT -BREWING UNIT FAULT-

The control microswitch indicates that the coffee unit is not in the infusion position.

COFFEE UNIT -DISPENSING UNIT FAULT-

During the infusion phase, the control microswitch signals the movement of the espresso unit.

COFFEE UNIT -UNIT DISCHARGE FAULT-

At the end of the infusion, the control microswitch signals that the coffee unit does not reach the "used pod discharge" position.

COFFEE UNIT -UNIT IDLE FAULT-

The control microswitch indicates that the brewing unit did not go back to the idle position after the discharge of the pod.

BOILER ERROR

The operating temperature of the boiler is not reached after several temperature measurements in a given time.

The appliance has been taken out of service.

STEAM BOILER ERROR

The operating temperature of the boiler is not reached after several temperature measurements in a given time.

The appliance has been taken out of service.

BOILER LEAK

Signals a possible loss of boiler pressure during a "pressurised" cycle.

FULLY CLEANING THE MACHINE

Signals that the appliance needs to be fully cleaned.

The warning is displayed when the set time limit or number of selections is reached.

WASHING THE ESPRESSO UNIT USING PODS

Signals that the espresso unit needs to be cleaned with sanitising pods.

The warning is displayed when the set time limit or number of selections is reached.

FULLY WASHING THE CAPPUCCINO MAKER

Signals that the milk circuit needs to be fully washed (with detergent).

WASHING THE CAPPUCCINO MAKER

Signals that the milk circuit needs to be washed/ rinsed.

WASHING THE MIXERS

Signals that the mixers need to be washed. The warning is displayed when the set time limit or number of selections is reached.

COIN BOX

For models with a payment system only. The machine will lock if it receives a pulse lasting more than 2 seconds on a validator line or if the communication with the serial coin box is interrupted for longer than 30 (Executive protocol) or 75 (BDV protocol) seconds.

LIQUID RESIDUE CONTAINER MISSING

The liquid residue container has not activated the microswitch which indicates the presence of the container.

Check that the liquid residue container has been correctly positioned inside the appliance.

NO WATER

Lack of water from the mains or internally-supplied tank.

Make sure that the machine is connected to the water mains and that the tap is open or the tank is full of water.

Tap the "Reset" button to restore the appliance's operation.

NO COFFEE

If the dose of ground coffee in the doser is not reached within 15 seconds, the "no coffee" fault is recorded.

GRINDER SHUTDOWN

A sensor detects the effective rotation of the grinder during the grinding time.

In the event of a blockage (due to foreign bodies, etc.) the grinder is shutdown and the espresso-based selections are disabled.

This option can be used to enable/disable the grinder rotation check.

MACHINE BOARD

Lack of communication between the machine board and the CPU board.

Check the electrical connections between the two boards.

ESPRESSO TEMPERATURE LOW

The espresso boiler temperature is lower than the minimum temperature that has been programmed for dispensing espressos.

Wait for the minimum dispensing temperature that has been set to be reached.

MACHINE DATABASE NOT AVAILABLE

The database that groups together and manages the machine configurations is missing on the appliance, it cannot be loaded or created.

Make sure there is sufficient memory space.

ESPRESSO CONTAINER IS MISSING

A sensor detects the coffee container(s).

If the sensor does not detect anything, the grinder is disabled.

The coffee container(s) has not been detected by the sensor, is incorrectly positioned or has not been repositioned in the appliance.

INSTANT CONTAINER IS MISSING

A sensor detects the instant powder container(s).

The instant powder container(s) has not been detected by the sensor, is incorrectly positioned or has not been repositioned in the appliance.

MILK PUMP

It is displayed when:

- The milk pump has a high current absorption (the pump is blocked).
- The milk pump has no current absorption (the pump is disconnected).
- The milk pump is working but its rotation has not been detected (no signal has been received from the pump's encoder).

STATISTICS

SHOW STATISTICS

Displays the selection statistics (e.g. the number of dispenses carried out, time and date of the last dispense, etc.)

RESET STATISTICS

Resets the stored statistics of the selections.

SHOW AUDIT

Displays the total number of dispenses and the total dispenses since the last statistics reset, for each selection.

The function allows the audit data that is shown to be filtered by category.

NUMBERING SELECTIONS

Allows the selections to be numbered and match the selection number-beverage in the statistics.

FAVOURITES

"Favourites" are shortcuts to frequently used functions.

After having added a function to the "favourites," simply view the "favourites" and tap the function for quick access.

LIST OF FAVOURITES

Displays all frequently used functions that have been saved as "favourites"

Tap the selected function to access it.

REMOVE A FUNCTION FROM "FAVOURITES":

- From the list of favourites, tap the "bin" icon.
- Tap the function to be removed from favourites.

CLEAR THE LIST OF FAVOURITES

Removes all functions from the list of "favourites".

MACHINE IDENTIFICATION

Allows you to enter a numerical code and name to identify the appliance.

The code can be used to identify the appliance when analysing the statistics.

INSTALLATION DATE

Allows the date that the appliance was installed to be set.

Use  to set the date.

(i) The date is used to manage maintenance intervals and automatic wash/rinse cycle intervals.

TECHNICAL SUPPORT CONTACT INFORMATION

Allows the contact information (name and phone number) of the technical support to be entered, in the event of faults.

This information will be displayed should a fault occur.

This information can be displayed for faults which block the appliance and/or faults which do not block the appliance, or for faults which cannot be reset during normal operation.

Use  to edit the contact information.

ENERGY SAVING MODE

The appliance's energy saving function can be enabled, its parameters modified and its time frames set.

SETTINGS

Enables / disables power saving features.

The appliance can manage various energy saving profiles.

Some of the parameters in every energy saving profile can be customised.

“SOFT MODE” PROFILE

This profile enables the energy saving mode after the appliance has a period of inactivity.

When a selection is requested, the machine exits the energy saving mode.

It is possible to:

- Set after how many minutes of appliance inactivity to activate the energy saving profile.
- Set the maintenance temperature of the boiler(s) in the energy saving mode.
- Enable/ disable the appliance's lighting.
- Select the touchscreen brightness level from those that have been predefined.

“DEEP MODE” PROFILE

This profile is active during the set time frames.

During the set time frames, the boiler temperature is lowered and the maintenance temperature is set.

It is possible to:

- Set by how many minutes to advance the boiler's heating before the end of the of the time frame.
E.g. 5 minutes: 5 minutes before the end of the time frame, the boiler heating cycle is activated in order to reach the operating temperature.
- Set the maintenance temperature of the boiler(s) in the energy saving mode.
- Enable/ disable the appliance's lighting.
- Select the touchscreen brightness level from those that have been predefined.

TIME FRAMES

Allows the time frames of the energy saving profiles to be set.

- Select the day for which the time frames will be set.
- Tap the “+ Add” button then the line of the profile to position a rectangle indicating the time.
- Drag the rectangle to precisely define the time.

To eliminate a rectangle, tap the “- Remove” button, then tap the rectangle to be eliminated.

Settings made for the entire week or a single day can be copied.

Tap “Copy day profile” to be able to:

- Copy the time frames that have been set for a single day of the week; tap the day to set the energy saving mode to and then tap “paste daily profile”.
- Copy the time frames that have been set for all days of the week; tap “paste daily profile to all days”.

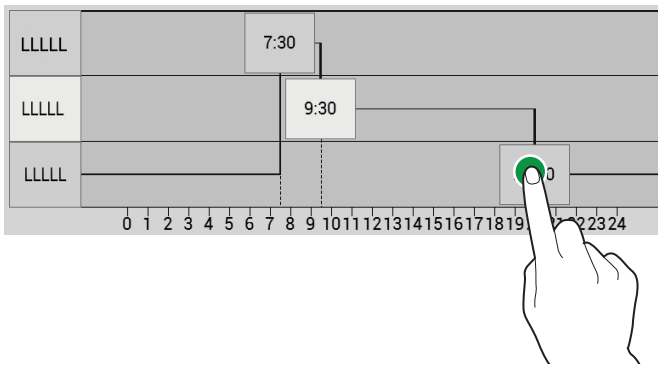

Fig. 40

PAYMENT SYSTEMS

It is possible to decide which of the payment system protocols to enable and which functions to manage.

Some of the parameters, which are used in numerous payment systems, keep the set value even if the system type is changed.

COMMON PARAMETERS

IMMEDIATE CHANGE

Usually the amount for a selection is cashed in after the appliance sends the “Selection made” signal.

By enabling this function, which is disabled by default, the payment signal is sent when the beverage starts being dispensed.

Setting this parameter is compulsory.

DECIMAL POINT POSITION

Set the decimal point position, i.e.:

- 0: decimal point is disabled
- 1: XXX.X (one decimal place)
- 2: XX.XX (two decimal places)
- 3: X.XXX (three decimal places)

TYPE OF DISPENSING

This allows you to set the operating mode for multiple or single dispenses. With multiple dispensing, the change is not automatically returned when one beverage has finished being dispensed; it remains available for further dispenses. When the return coins button is pressed, the remaining credit will be returned if its value is less than the maximum change value.

OBLIGATION TO BUY

This enables/ disables the return coins button before a product is dispensed.

- ON: the change is returned after a product has been selected.
- OFF: the change is returned immediately when the return coins button is pressed (the appliance works as a change machine).

VALIDATOR

DECIMAL POINT POSITION

Set the decimal point position, i.e.:

0: decimal point is disabled

1: XXX.X (one decimal place)

2: XX.XX (two decimal places)

3: X.XXX (three decimal places)

CREDIT PROGRAMMING (OVERPAY)

You can decide whether to:

- Collect any credit in excess of the selection amount after a certain time in seconds (parameter "000 deleted").

- Leave any credit in excess of the selection amount available for a subsequent selection (parameter "kept").

OVERPAY TIMEOUT

Makes it possible to set the time when the credit will be released if a selection hasn't been made.

MDB

CREDIT PROGRAMMING (OVERPAY)

You can decide whether to:

- Collect any credit in excess of the selection amount after a certain time in seconds (parameter "deleted").

- Leave any credit in excess of the selection amount available for a subsequent selection (parameter "kept").

OVERPAY TIMEOUT

Makes it possible to set the time when the credit will be released if a selection hasn't been made.

MAXIMUM CREDIT

This function allows the maximum credit accepted for the introduced coins to be defined.

MAXIMUM CHANGE

It is possible to set a limit for the total amount of change that the coin box will give when the return change button is pressed or after a single dispensed beverage.

Any credit exceeding the amount that has been programmed with this function, will be cashed in.

ACCEPTED COINS

It is possible to define which coins that are recognised by the validator shall be accepted when the coin return tubes are full.

For the coin/ value correspondence, the configuration of the coin box needs to be checked.

EXACT CHANGE ACCEPTED COINS

It is possible to define which coins that are recognised by the validator shall be accepted when the machine is in "exact change" mode.

For the coin/ value correspondence, the configuration of the coin box needs to be checked.

RETURNED COINS

It is possible to define which coins among those available in the tubes shall be used for giving change. This parameter is only active with coin boxes which do not automatically choose which tube to use (Auto changer payout).

For the coin/ value correspondence, the configuration of the coin box needs to be checked.

EXACT CHANGE ALGORITHM

This allows the control algorithm to be chosen so that the machine is able to give change when the selection has been made.

Each algorithm checks a set of conditions (the amount of coins in the tubes or the empty or full status) in the tubes which is then used by the coin box to give change.

The "Doesn't give change" condition occurs when the tubes combined with the chosen algorithm have reached the minimum level of coins.

For the sake of simplicity, the combination is described in reference to tubes A, B and C, where tube A receives the lower value coins and tube C, the higher value coins.

0	=	A or (B and C)
1	=	A and B and C
2	=	only A and B
3	=	A and (B or C)
4	=	only A
5	=	only A or B (default)
6	=	A or B or C
7	=	only A or B
8	=	only A or C
9	=	only B and C
10	=	only B
11	=	only B or C
12	=	only C

E.g.: algorithm "6" will display the "Doesn't give change" message when all tubes (A,B and C) are at the minimum level.

Algorithm "04" will only display the "Doesn't give change" message when tube A (coin with the least value) has reached its minimum coin level.

PRICES

CURRENCY SYMBOL

When the credit is displayed, this function can set the currency symbol from those that have been predefined.

SELLING PRICES

The appliance (depending on the payment method) can manage up to 4 different prices for each selection.

The prices can be active according to the time frame that has been set (standard or promotional).

The prices are grouped into 4 lists.

For each of the 4 lists, the price can be set both in a comprehensive manner (same price for all selections) or an individual manner (for each single selection).

FREE VEND PASSWORD

Enables / disables the free dispensing of one or more selections via a password.

Set:

-the password for one free dispensed beverage

or

-the password to dispense multiple selections for free.

PRICE PER TIME FRAME

Allows the time frames (standard or promotional) to be set for sales at differentiated prices.

- Tap the day for which the time frames will be set.
- Tap the “add” button then the line of the time frame in order to position a rectangle indicating the time.
- Drag the rectangle to precisely define the time.

To eliminate a rectangle, tap the “remove” button, then tap the rectangle to be eliminated.

Settings made for the entire week or a single day can be copied.

Tap “Copy day” to be able to:

- Copy the time frames that have been set for a single day of the week; tap the day to set the energy saving mode to and then tap “paste day”.
- Copy the time frames that have been set for all days of the week; tap “paste to all days”.

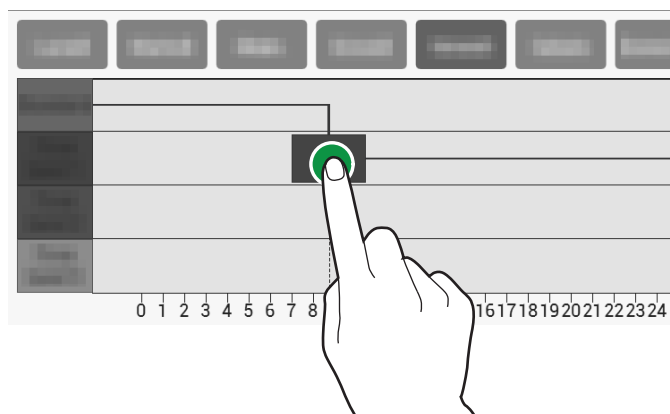

Fig. 41

IMPORT/ EXPORT

Includes all the export and import statistic functions, machine settings, graphics packages, etc.

EVA-DTS

Allows EVA-DTS data to be exported onto a USB stick and/or onto data transmission devices (RS232, IrDA, telemetry, etc.).

USB

Saves a EVA-DTS file onto the USB stick.

SERIAL COMMUNICATION PROTOCOL

From this function it is possible to decide which communication protocol to use for communication with the data acquisition devices.

DDCMP - EDDCMP

These have the following configurable parameters:

- **Baud rate:** is the transmission speed to be used in communications between the appliance and data acquisition devices.
- **Pass code:** this is a code which must be the same as the data transfer terminal, in order to be identified. The default setting is 0.
- **Security code:** this is a code for mutual recognition between the appliance and the EVA-DTS terminal. The default setting is 0.
- **End of transmission:** if enabled, it can identify the end of transmission signal (EOT) which is sent with the last packet and interrupt the data transmission.

DEX/UCS

These have the following configurable parameters:

- **Baud rate:** is the transmission speed to be used in communications between the appliance and data acquisition devices.

VIDEOS

Allows videos to be imported/ exported from the appliance via a USB stick.

SUPPORTED VIDEO FORMATS

- MP4 codes H264 and 25 frames/sec
- AVI codes XVID, MPEG2 and 25 frames/sec
- MOV codes MPEG4 and 25 frames/sec
- Maximum screen saver resolution: 1200x800
- Entertainment video resolution: 640x480.

(i) The use of high-quality content will affect the overall performance of the appliance and use up memory space.

⚠ Playing videos may require the authorisation of the copyright owner or other rights related to the content itself.

Make sure to comply with the copyright laws that are in force in the country where the appliance is installed.

IMAGES

Allows images to be imported/ exported from the appliance via a USB stick.

SUPPORTED IMAGE FORMATS

- JPG, PNG

(i) The use of high-quality content will affect the overall performance of the appliance and use up memory space.

⚠ Showing images may require the authorisation of the copyright owner or other rights related to the content itself.

Make sure to comply with the copyright laws that are in force in the country where the appliance is installed.

LOGFILE ERRORS

Exports the errors found on the machine into a logfile.

It is stored onto a USB stick.

SYSTEM

COMPONENT TEST

Allows the appliance's main components to be checked.

The components that can be checked are displayed.

Choose the component to be checked.

BREWING UNIT

Starts moving the brewing unit.

ESPRESSO CONTAINER

A dose of coffee beans is ground.

MOTOR-DOSER

The instant powder motor-doser is activated for a few seconds.

MIXER

The mixer is activated for a few seconds.

LIGHTING

The appliance's lighting is activated for a few seconds.

SOLENOID VALVES

The selected solenoid valve is activated for a few seconds.

PUMPS

The selected pump is activated for a few seconds.

⚠ During the test, hot water is dispensed: do not put your hands in the dispensing area.

SENSOR AND INPUT DEVICE TESTS

Displays the status of the appliance's various sensors and/or controls (probes, micro-switches, etc.)

For devices with ON/OFF functions, the status is shown using colour: green is used if the appliance is active/ actuated, and red is used if it is disabled/ not been actuated.

For the sensors, the detected value is displayed (e.g. temperature).

OUTPUT DEVICE TESTS

Allows the operation of the appliance's various components to be checked.

The components that can be checked are displayed.

Choose the component to be tested.

ⓘ For safety reasons the tests must be carried out with the door closed.

Press and hold down the component button to activate it and to check that it is working.

When the button is released, the component will be turned off.

TOUCHSCREEN TEST

Allows the touchscreen function to be checked.

Tap and drag your finger across the touchscreen.

Each tap leaves a different-coloured trace.

FILLING AND EMPTYING THE BOILER

The boiler can be filled and emptied.

The hydraulic circuit is automatically filled.

If work is performed on the hydraulic circuit or if significant water pockets start forming, manually fill the hydraulic circuit.

The boiler emptying function opens a solenoid valve to allow air to enter the boiler.

FILLING THE BOILER

The boiler is automatically filled when the appliance is installed.

Use this function to fill the boiler after maintenance work has been performed on the hydraulic system or if significant water pockets form.

EMPTYING THE BOILER

The boiler must be emptied by technical personnel.

⚠ The boiler water is very hot and can cause burns.

ⓘ Before emptying the boiler, wait for the water in the boiler to cool down.

The appliance has a procedure for "quickly cooling" the boiler.

The emptying function opens a solenoid valve to allow air to enter the boiler.

MACHINE PARAMETER TESTS

Sets the activation time of the components during the self-test.

RESTORE FACTORY SETTINGS

Allows the appliance to be restored to its factory settings.

ⓘ All the statistical data, fault lists and settings will be lost.

TIME AND DATE SETTINGS

The time and date are used to record events (for example faults, etc.), manage programmed washes and produce maintenance warnings.

Set the current date and time.

LANGUAGE

The predefined language used to display messages on the user interface and in the menus can be changed.

Some languages are available for the "change language" function.

USER PROFILES

Some programming functions can be enabled/ disabled via the access profiles.

The access profile ensures that only the functions linked to it can be used.

Each user profile has an access password.

The default passwords are:

-Technician (4444)

-Distributor (3333)

-Loader (2222)

-User (1111)

Advanced programming functions must only be used by people with specific knowledge of the appliance (technical personnel) and hygiene regulations.

This function can be used to change the access password for each user profile; tap the keypad icon to change the password.

SOFTWARE UPDATE

Shows the software version of the appliance.

It also allows the appliance's software to be updated via a USB stick or via a network connection.

UPDATING VIA A USB

The appliance's software can be updated via a USB stick.

- Insert the USB stick which contains the new software.
- Browse the file system of the USB stick and select the file with the software update.

INFORMATION

Allows all of the information regarding the appliance's software to be viewed (version, graphic theme used, machine configuration, etc.).

Chapter 3 Maintenance

The integrity of the appliance and its compliance with the corresponding system regulations must be checked, at least once a year, by specialised personnel.

i Always disconnect the appliance from the electric mains before starting any maintenance work which requires disassembling components.

The operations described below must solely be carried out by personnel with specific knowledge of the appliance's operation, both from an electrical safety and hygiene point of view.

GENERAL INTRODUCTION

In order to ensure its correct operation, the machine shall be subject to periodical maintenance.

Listed below are the operations to be carried out and the frequency with which they should be carried out; they are evidently indicative because they depend on the conditions of use (i.e. water hardness, environment humidity and temperature, type of product used, etc.).

The operations described in this chapter do not include all of the maintenance interventions.

The more complex interventions (i.e. descaling the boiler) shall be carried out by a technician with specific knowledge of the vending machine.

In order to generally avoid risks of oxidation or chemical aggressions, the painted and stainless steel surfaces need to be kept clean using neutral detergents (avoid using solvents).

Under no circumstances must jets of water be used to wash the appliance.

MAIN SWITCH AND FUSE

To access the appliance's main switch and line fuse, remove the solid and liquid residue containers.

Important!

The line cable terminal block, line fuse, and noise filter are always powered.

Inside the appliance, only the parts that are marked with the symbol below remain live.



The protective covers need to be removed after disconnecting the appliance from the power supply.

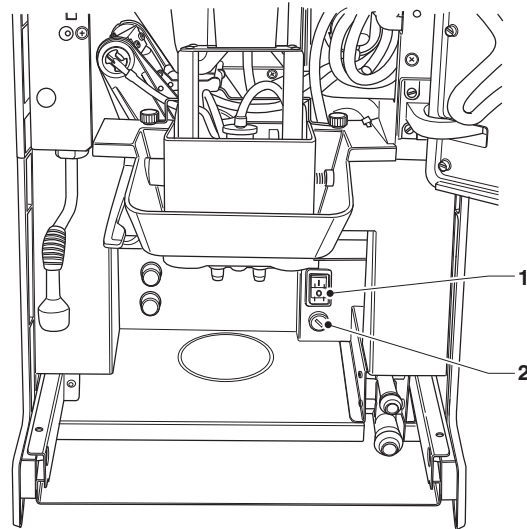

Fig. 42

1. Main switch
2. Line fuse

MAINTAINING THE BREWING UNIT

Z4000

After 10 000 dispensed items or every 6 months, the coffee group requires a small amount of maintenance work in order to optimise how it works over time.

To perform the maintenance work, the unit needs to be removed as follows:

1. Disconnect the coffee outlet nozzle from the unit by rotating it 90° away from the connecting rod and pull it outwards.
2. Turn the unit end stop lever, rotating it until it is in a horizontal position.
3. Remove the coffee unit.

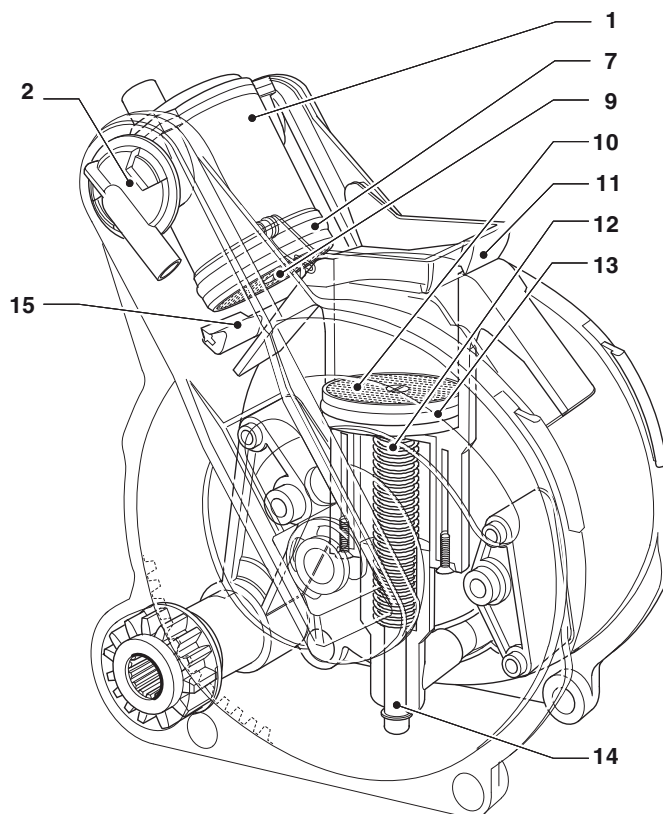
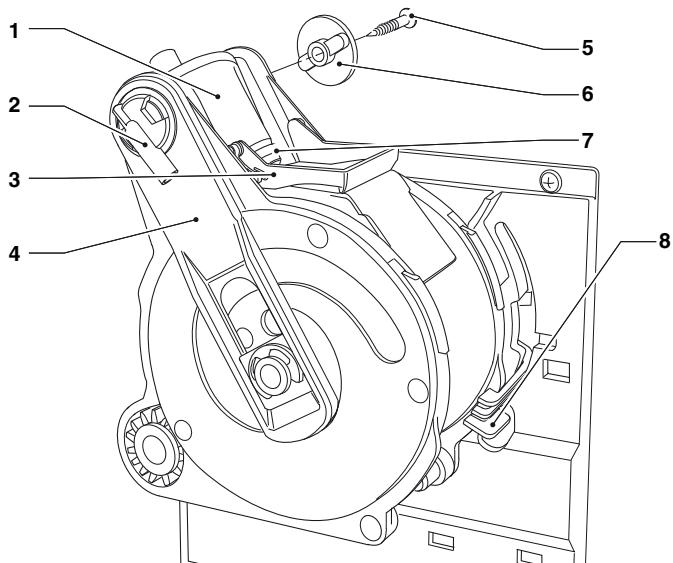

Fig. 43

1. Upper piston
2. Coffee outlet nozzle
3. Lower scraper
4. Connecting rod
5. Lateral screw
6. Key
7. Upper seal
8. Unit end stop lever
9. Upper filter
10. Lower filter
11. Lower scraper
12. Lower piston
13. Lower seal
14. Piston guide ring
15. Upper scraper
16. Unit cover

REMOVING/ REPLACING THE UPPER FILTER AND SEAL

In order to remove or replace the filter and the upper seal, proceed as follows:

1. Unscrew the upper piston key's (6) lateral fixing screw (5).
2. Rotate the upper piston (1) upwards.
3. Remove and replace the upper seal (7).
4. Unscrew the upper filter (9) so that it can be removed and replaced.

REMOVING/ REPLACING THE LOWER FILTER AND SEAL

In order to remove or replace the lower filter and seal, proceed as follows:

1. Manually bring the unit to the discharge position with the lower piston (12).
2. Unscrew the central fixing screw to remove the filter (10).
3. Press on the end of the piston guide ring (14) to obtain an extra stroke from the lower piston (12).
4. Using a small screwdriver, pry and slide the lower piston (12) out from the piston rod (14) whilst being careful not to damage the piston or the sealing elements.
5. Remove and replace the lower seal (13).

MAINTAINING THE BREWING UNIT

Z4000 ESFB

After 10 000 dispensed items or every 6 months, the brewing unit requires a small amount of maintenance work in order to optimise how it works over time.

To perform the maintenance work, the brewing unit needs to be removed:

1. Disconnect the espresso coffee outlet nozzle from the unit by rotating it 90° away from the connecting rod and pulling it outwards.
2. Disconnect the fresh brew coffee outlet nozzle from the unit by rotating it 90° and pulling it out.
3. Turn the unit end stop lever, rotating it until it is in a horizontal position.
4. Remove the brewing unit.

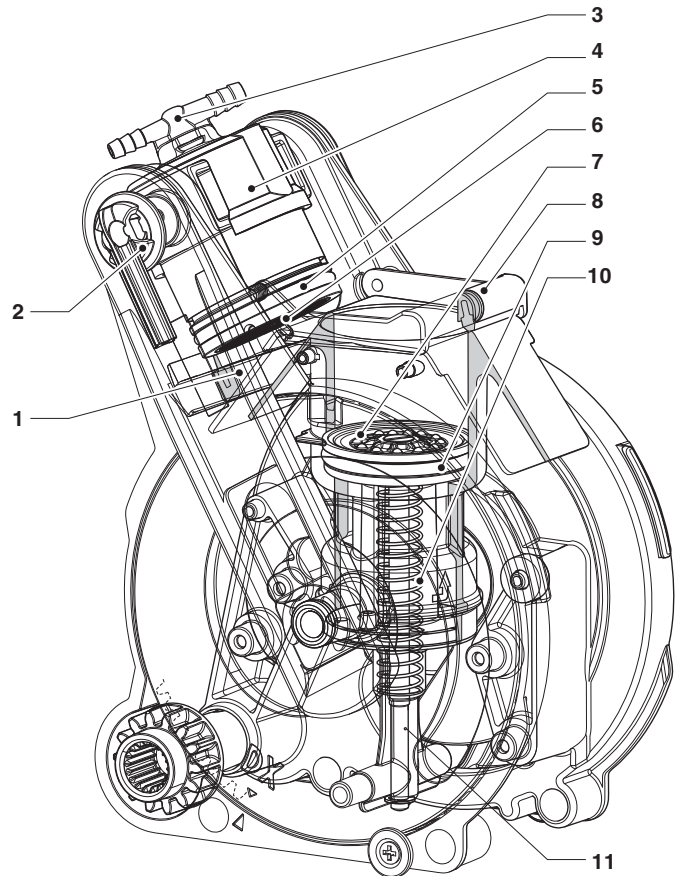

Fig. 45

1. Upper scraper
2. Espresso nozzle
3. Fresh Brew nozzle
4. Upper piston
5. Upper piston seal
6. Upper filter
7. Lower filter
8. Lower scraper
9. Lower piston seal
10. Lower piston spring
11. Piston rod

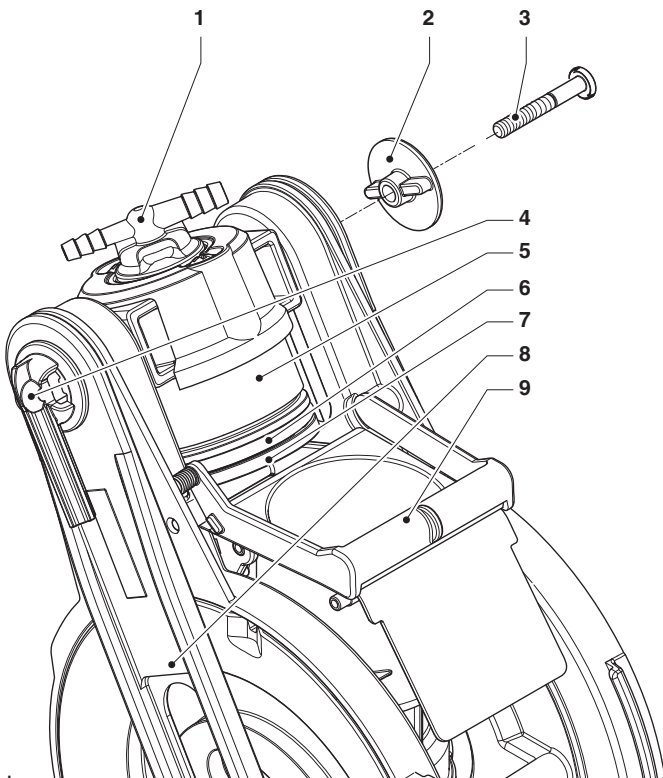

Fig. 44

1. Fresh Brew nozzle
2. Key
3. Lateral screw
4. Espresso nozzle
5. Upper piston
6. Upper piston seal
7. Upper filter
8. Connecting rod
9. Lower scraper

REMOVING/ REPLACING THE UPPER FILTER AND SEAL

In order to remove or replace the filter and the upper seal, proceed as follows:

1. Unscrew the key's lateral fixing screw.
2. Rotate the upper piston upwards.
3. Remove and replace the upper seal.
4. Unscrew the sealing ring to remove the upper filter.

(i) Reinsert the filter holder whilst making sure that the flat surface is facing upwards.

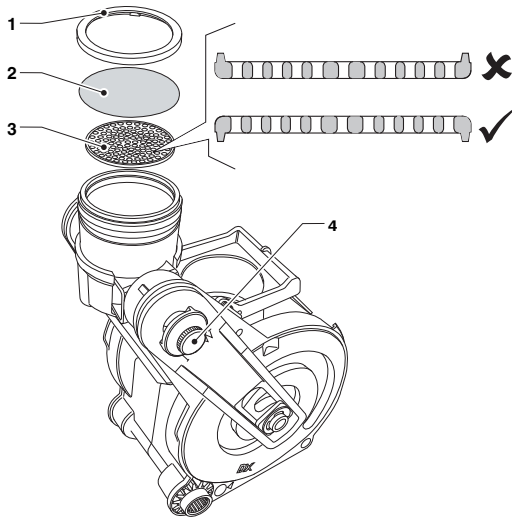

Fig. 46

1. Sealing ring
2. Upper piston filter
3. Upper piston filter support
4. Screw

REMOVING/ REPLACING THE LOWER FILTER AND SEAL

In order to remove or replace the lower filter and seal, proceed as follows:

1. Manually bring the unit to the discharge position with the lower piston in a high position.
2. Unscrew the central fixing screw to remove the filter.
3. Press on the end of the piston guide ring to obtain an extra stroke from the lower piston.
4. Using a small screwdriver, pry and slide the lower piston out from the piston rod whilst being careful not to damage the piston or the sealing elements.
5. Remove and replace the lower seal.

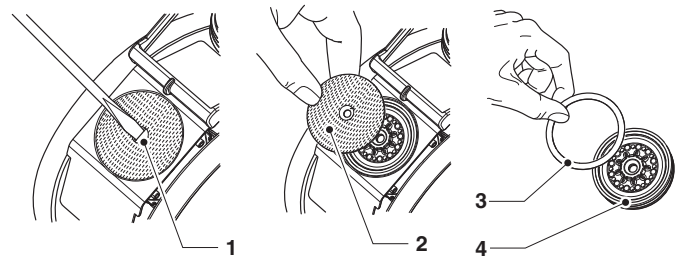

Fig. 47

1. Screw
2. Filter
3. Seal
4. Filter support

PERIODICAL OPERATIONS

This manual shows the potential weak points and includes information about controlling the possible growth of bacteria.

Under the current health and safety regulations, the operator of the appliance must apply the self-control procedures, identified in accordance with the HACCP (Hazard Analysis Critical Control Point) Directive and national legislation.

At least once a year, or more frequently depending on how the appliance is used and the quality of the incoming water, it is necessary to clean and sterilise the entire circuit and the parts which come into contact with the food products.

SANITISATION

- All the components which come into contact with the food products, including the tubes, must be removed from the appliance and all of their parts disassembled;
- All the residues and visible films must be mechanically removed using swabs and brushes if necessary;
- The components must be soaked for at least 20 minutes in a sterilising solution;
- The internal surfaces of the appliance need to be cleaned with the same sterilising solution;
- Rinse thoroughly and reassemble the various components.

Before restarting the appliance, the sterilising operations need to be carried out again with the installed components, as described in the "Cleaning the mixers and food products circuits" chapter.

MIXER

For appliances that dispense instant beverages, remove the components as follows:

1. Disconnect the hoses from the mixer connections.
2. Turn the mixer locking ring anticlockwise and remove the mixer. Take special care to fully lock it when reassembling it;
3. Separate the instant powder funnel, the powder tray and water funnel.

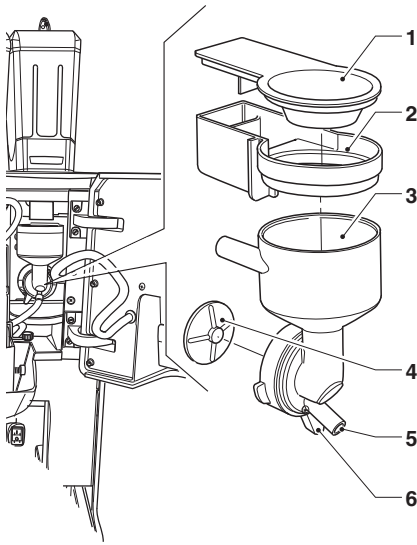

Fig. 48

1. Instant powder funnel
2. Instant powder tray
3. Water funnel
4. Mixer fan
5. Instant beverage hose connection
6. Mixer locking ring

4. Remove the fans: block the disk fitted on the motor mixer shaft with one finger, then unscrew the mixer fan.

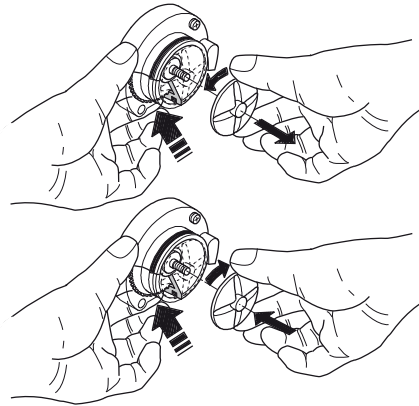

Fig. 49

5. Dip the parts for approx. 20 minutes in a recipient containing the previously-prepared sterilising solution. Wash all the components with sterilising products (follow the dosage indicated by the manufacturer), being careful to mechanically remove the residues and visible films using brushes and swabs if necessary.
6. Verify that the motor mixer's sealing gasket is not torn and has not lost its elasticity.
7. Reassemble the powder drawers and the powder funnels after having carefully rinsed and dried them.
8. Place the mixer back into position and make sure that the water funnel has been correctly inserted.

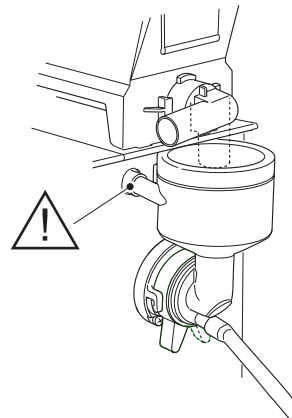

Fig. 50

After reassembling the components, it is necessary to:

Wash the mixer and add a few drops of the sanitising solution into the various funnels and rinse thoroughly to remove any residues from the solution that has been used.

DIFFUSER NOZZLE

For models with a diffuser nozzle only.

1. Unhook the diffuser nozzle from the support bracket.
2. Separate the diffuser nozzle components.
3. Start sanitising whilst taking care to mechanically remove residues and visible films using swabs or brushes, if necessary.
4. Thoroughly rinse the various components before reassembling them.

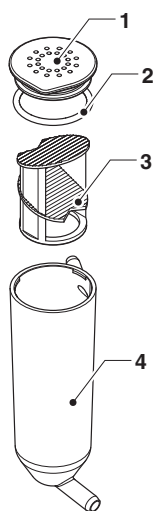

Fig. 51

1. Cover
2. Seal
3. Diffuser
4. Diffuser nozzle body

CLEANING THE NOZZLES AND SPOUTS

Weekly or more frequently, depending on how often the appliance is used and the quality of incoming water, it is necessary to sanitise the instant beverage dispensing ducts and nozzles.

To clean the nozzles, proceed as follows:

1. Pull down the handle of the telescopic nozzles.
2. Remove the cover and disconnect the hoses from the nozzles.
3. Disconnect the coffee dispensing hose from the flow divider nozzle.
4. Detach the flow divider nozzle from the nozzle support.
5. Remove the flow divider, milker nozzle (if present) and the instant beverage nozzles.
6. For models with a cappuccino maker, separate all the parts of the milker nozzle.
7. Proceed to sanitise all the components, taking care to mechanically remove residues and visible films using swabs or brushes, if necessary.

Clean the spouts (if any) with a cloth that has been dampened with sanitising solution.

MODELS WITH A CAPPUCCINO MAKER

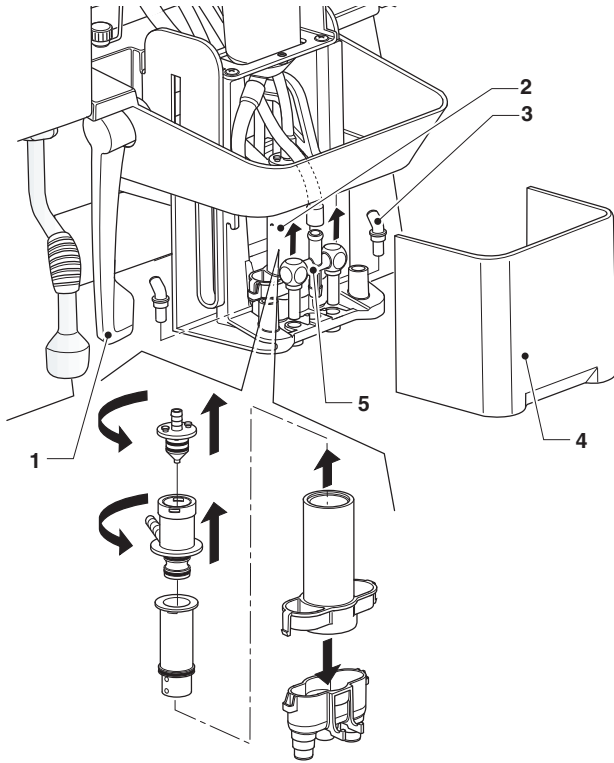

Fig. 52

1. Nozzle-moving handle
2. Mixer nozzle (models with a cappuccino maker only)
3. Instant beverage nozzles
4. Movable nozzle cover
5. Flow divider nozzle

MODELS WITHOUT A CAPPUCCINO MAKER

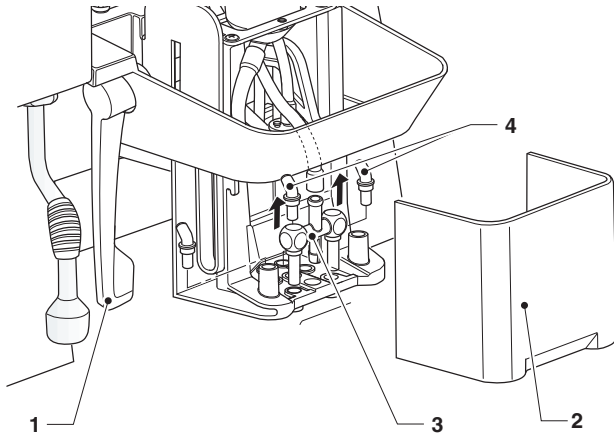

Fig. 53

1. Nozzle-moving handle
2. Movable nozzle cover
3. Coffee nozzle
4. Instant beverage nozzles

REMOVING THE PRODUCT CONTAINERS

The containers are fitted with a safety magnet which indicates the presence/absence of the containers to the control electronics.

If the sensor does not detect the containers, the grinders are disabled.

To remove the product containers (coffee beans or instant products) simply remove the handle and then lift the container from behind.

Always lift the container from behind so that the grinders are disabled; non-compliance with this procedure can be a source of injury to people (accidental operation of the grinder).

When the handle of the container is pulled, it closes the shutter and simultaneously releases a container from the appliance.

When reassembling, reposition the container and push the handle inside the container. Make sure that the container is properly secured to the appliance.

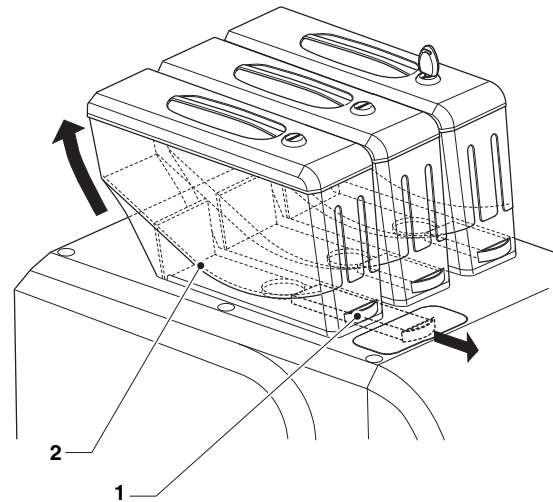

Fig. 54

1. Handle
2. Magnet

REMOVING THE SIDE AND REAR PANELS

To gain access to the internal components, the panels must be removed.

1. Remove the liquid residue container.
2. Remove the fixing screws of the side panels.
3. Remove the fixing knurls on the side panels.
4. Slide the side panels forward to release them.
5. To remove the rear panel, slide it to the left.

To reassemble the panels, repeat the process in reverse order.

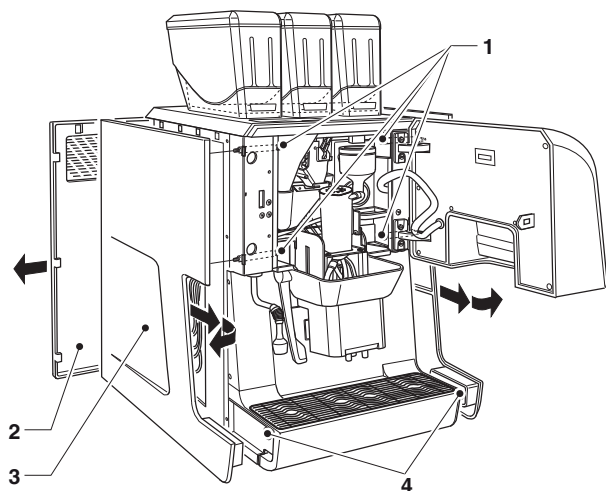

Fig. 55

1. Side panel fixing knurls
2. Rear panel
3. Side panel
4. Side panel fixing screws

CIRCUIT BOARD FUNCTIONS

The circuit boards are designed to be used on several models of appliances.

If the boards need replacing, the circuit board configuration must be checked and the suitable software loaded.

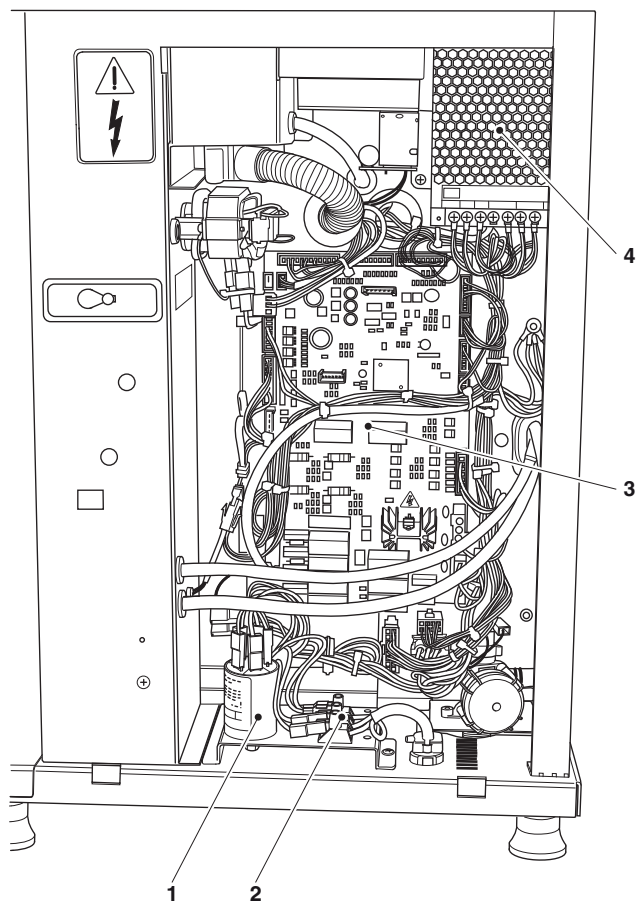
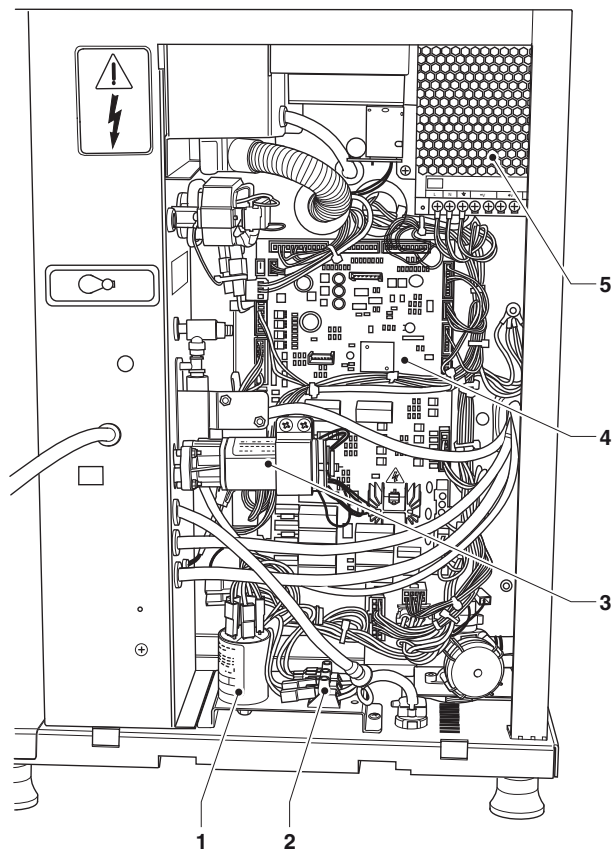

Fig. 56

1. Noise filter
2. Terminal board
3. Activation board
4. Power supply



POWER SUPPLY

The power supply provides a voltage of 24 Vdc to the appliance's electronics and the 24 Vdc components.

The power supply does not require calibration and/or maintenance.

Fig. 57

1. Noise filter
2. Terminal board
3. Milk pump
4. Activation board
5. Power supply

ACTIVATION BOARD

The board is powered at 24 V and controls the activation of the various users and sensor signals.

The LEDs indicate:

- DL1 (38) LED - RESET
- DL2 (19) LED - RUN; it flashes during normal operation
- DL3 (15) yellow LED - POWER; indicates the presence of +5 Vdc
- DL4 (17) yellow pulse LED - flow meter
- DL5 (15) not used
- DL6 (21) red LED indicates that the espresso heating element is working
- DL7 (20) red LED indicates that the steam heating element is working (if present)

RELAY FUNCTION

- RL1: Grinder
- RL2: Coffee release electromagnet
- RL3: Grinder 2*
- RL4: Coffee release electromagnet 2*
- RL5: Water pump
- RL6: Motor mixer
- RL7: 230 V safety relay
- RL9: 24V safety relay
- RL11: Grinder reverse rotation relay
- * Models with double coffee beans

The RL7 safety relay interrupts the neutral (230 V) when the door is opened.

The RL9 safety relay interrupts the 24V when the door is opened.

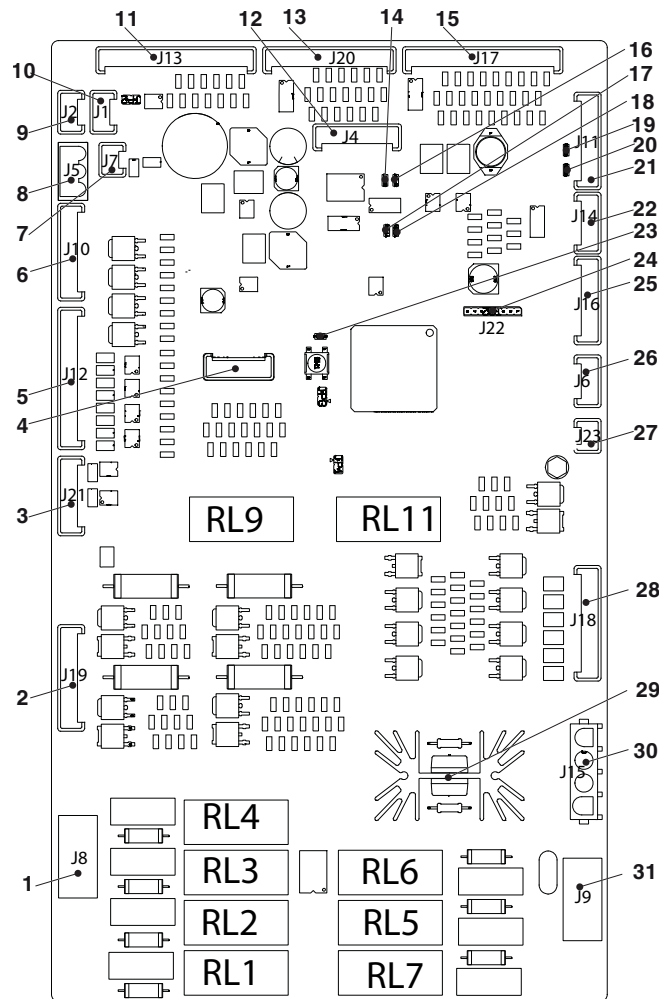

Fig. 58

1. (J8) Grinders, coffee release electromagnets, AC relay
2. (J19) Brewing unit motor, brewing unit control microswitch, milk pump*
3. (J21) Not used
4. Upkey
5. (J12) Solenoid valves, Cappuccino maker solenoid valves*, blenders
6. (J10) Mechanical stroke counter*
7. (J7) Not used
8. (J5) 24 Vdc board power supply
9. (J2) CAN Bus
10. (J1) CAN Bus
11. (J13) Digital inputs
12. (J4) Serial programmer
13. (J20) Not used
14. DL5 "Pulse flow meter" LED
15. (J17) Digital inputs
16. DL4 "Pulse flow meter" LED
17. DL1 "RESET" LED
18. DL2 "RUN" LED
19. DL7 Espresso boiler working LED
20. DL6 Steam boiler working LED
21. (J11) Boiler probes
22. (J14) Containers present
23. DL3 "POWER" LED
24. (J22) Expansion board
25. (J16) Dispensing compartment light*
26. (J6) Steam suction fans
27. (J23) Steam boiler water level
28. (J18) Grinder adjustment*, motor-doser
29. Triac heating element(s)
30. (J15) Heating elements
31. (J9) Motor-grinder, water pump, AC relay

* If present

BOILER THERMAL PROTECTION

A safety thermostat protects the boiler(s) from overheating by deactivating the boiler heating element should a fault occur in the control system.

The thermostat intervenes if the internal water temperature exceeds the safety threshold.

i If work needs to be carried out on the thermostat, it is necessary to wait for the boiler to cool down before identifying the cause of the failure and manually resetting the thermostat.

⚠ If the safety thermostat intervenes, it needs to be replaced along with the boiler. The temperature probe and sealing gaskets of the connections, may have been irreversibly damaged.

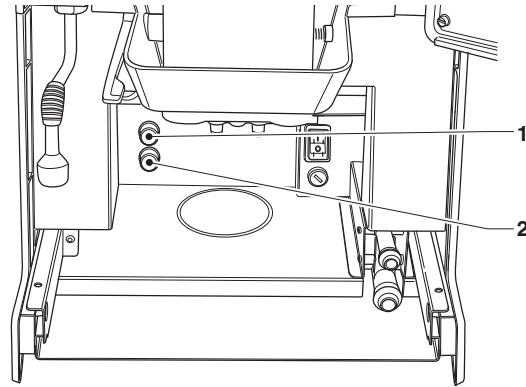

Fig. 59

1. Steam boiler safety thermostat*
2. Boiler safety thermostat

* models with a cappuccino maker

INSTALLING AND/OR UPDATING SOFTWARE

The software must be installed and/or updated (when the appliance starts up) using a USB stick.

(i) The USB stick must be completely empty and FAT32-formatted.

The software installation and/or update deletes all previous settings.

TOUCHSCREEN

Proceed as follows:

1. Copy the software files onto the USB stick.
2. Turn off the appliance.
3. Insert the USB stick into the “CPU touchscreen” screen.
4. Turn on the appliance.
5. A message will appear saying that the update is in progress.
The update can take several minutes.
6. Once the update has finished, a message will appear prompting for the USB stick to be removed.
7. The appliance will automatically restart.

SOFTWARE AND APPLICATION

Proceed as follows:

1. Copy the application files onto the USB stick.
2. Turn off the appliance.
3. Insert the USB stick into the “CPU touchscreen” screen.
4. Turn on the appliance.
5. A message will appear saying that the update is in progress.
The update can take several minutes.
6. Once the update has finished, a message will appear prompting for the USB stick to be removed.
7. The appliance will automatically restart.

Appendix

HYDRAULIC CIRCUIT

ESPRESSO

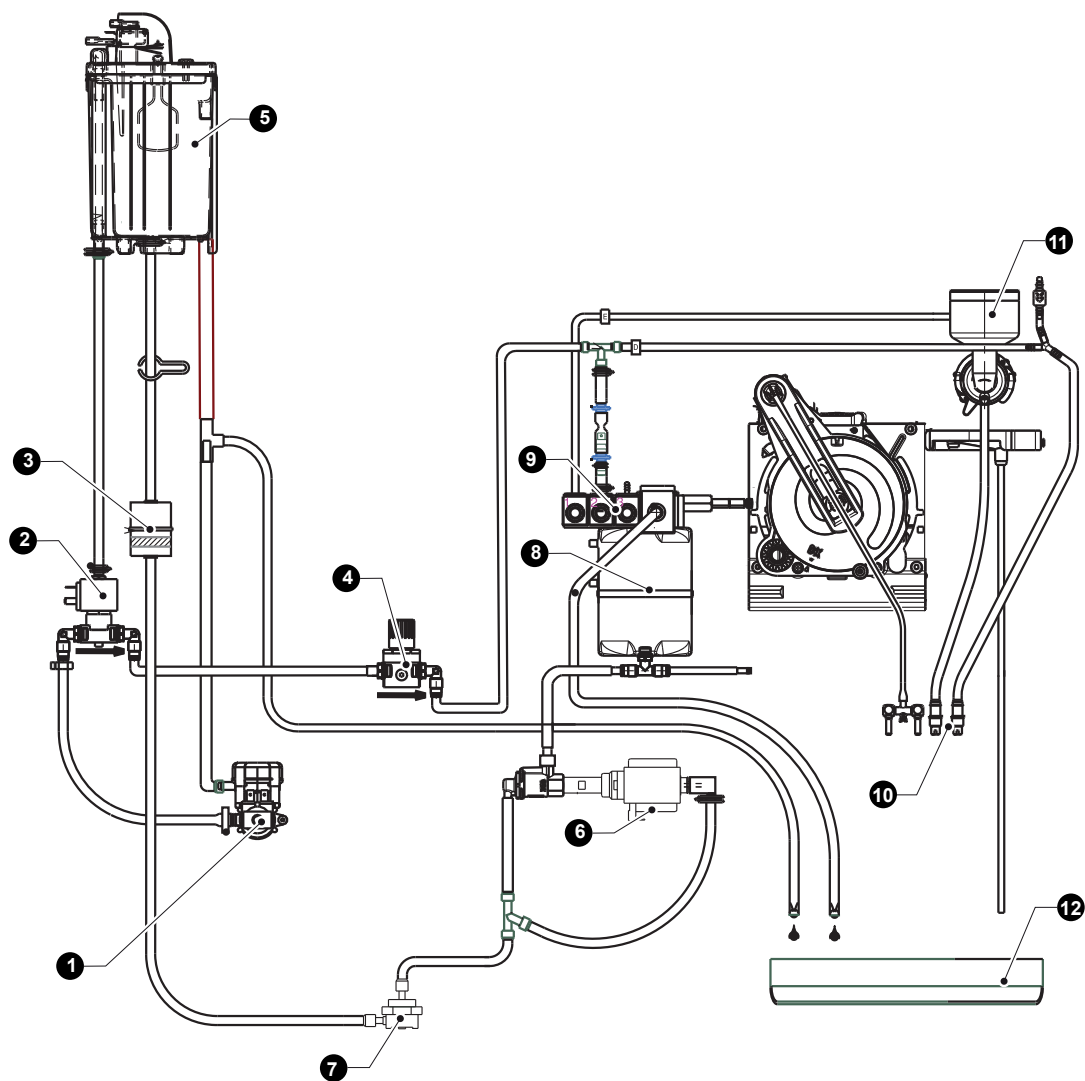

- 1. mains water solenoid valve
- 2. mixer solenoid valve*
- 3. filter
- 4. pressure reducer*
- 5. air break
- 6. pump
- 7. flow meter
- 8. boiler
- 9. solenoid valves
- 10. dispensing nozzles
- 11. mixer

- 12. liquid residue container

* for models with a mains water mixer only

HYDRAULIC CIRCUIT

ESPRESSO WITH CAPPUCCINO MAKER

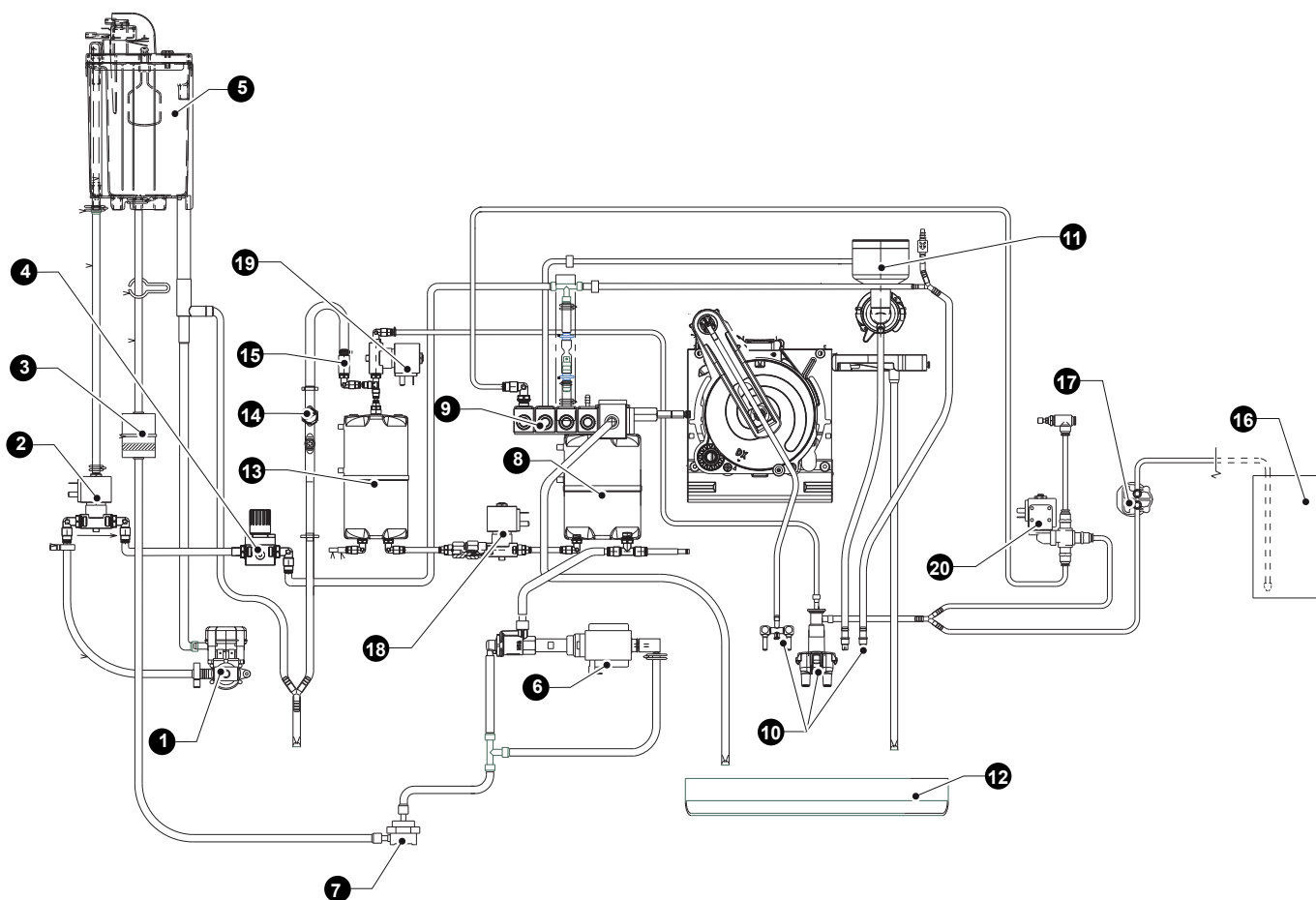

- 1. mains water solenoid valve
- 2. mixer solenoid valve
- 3. filter
- 4. pressure reducer*
- 5. air break
- 6. pump
- 7. flow meter
- 8. boiler
- 9. solenoid valves
- 10. dispensing nozzles
- 11. mixer

- 12. liquid residue container
- 13. steam boiler
- 14. thermostat
- 15. safety valve
- 16. milk tank
- 17. milk pump
- 18. steam boiler filling solenoid valve
- 19. steam solenoid valve

* for models with a mains water mixer only

HYDRAULIC CIRCUIT

ESPRESSO - FRESH BREW

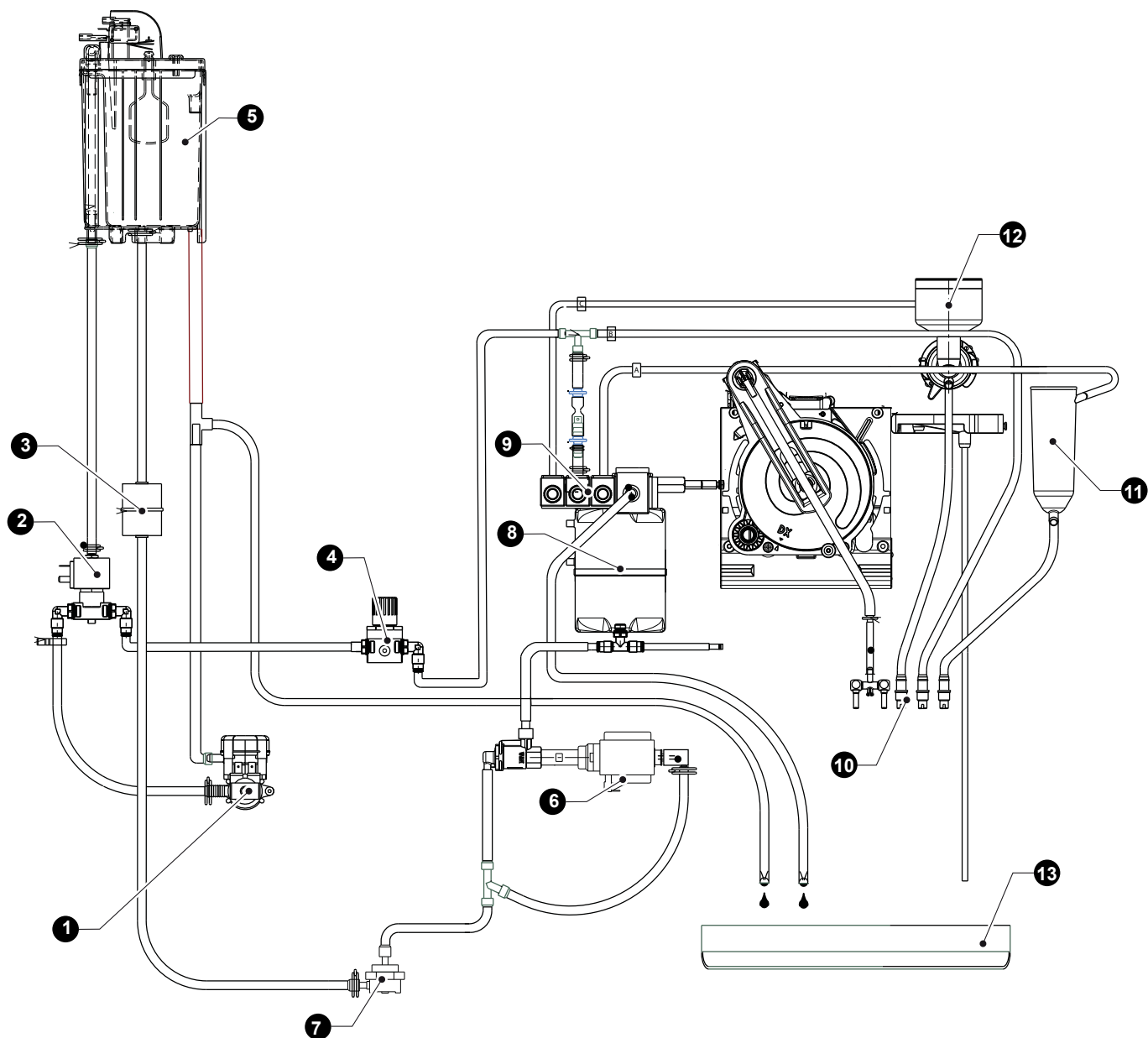

- 1. mains water solenoid valve
- 2. mixer solenoid valve*
- 3. filter
- 4. pressure reducer*
- 5. air break
- 6. pump
- 7. flow meter
- 8. boiler
- 9. solenoid valves
- 10. dispensing nozzles
- 11. diffuser nozzle

- 12. mixer
- 13. liquid residue container

* for models with a mains water mixer only

HYDRAULIC CIRCUIT

ESPRESSO - FRESH BREW WITH CAPPUCCINO MAKER

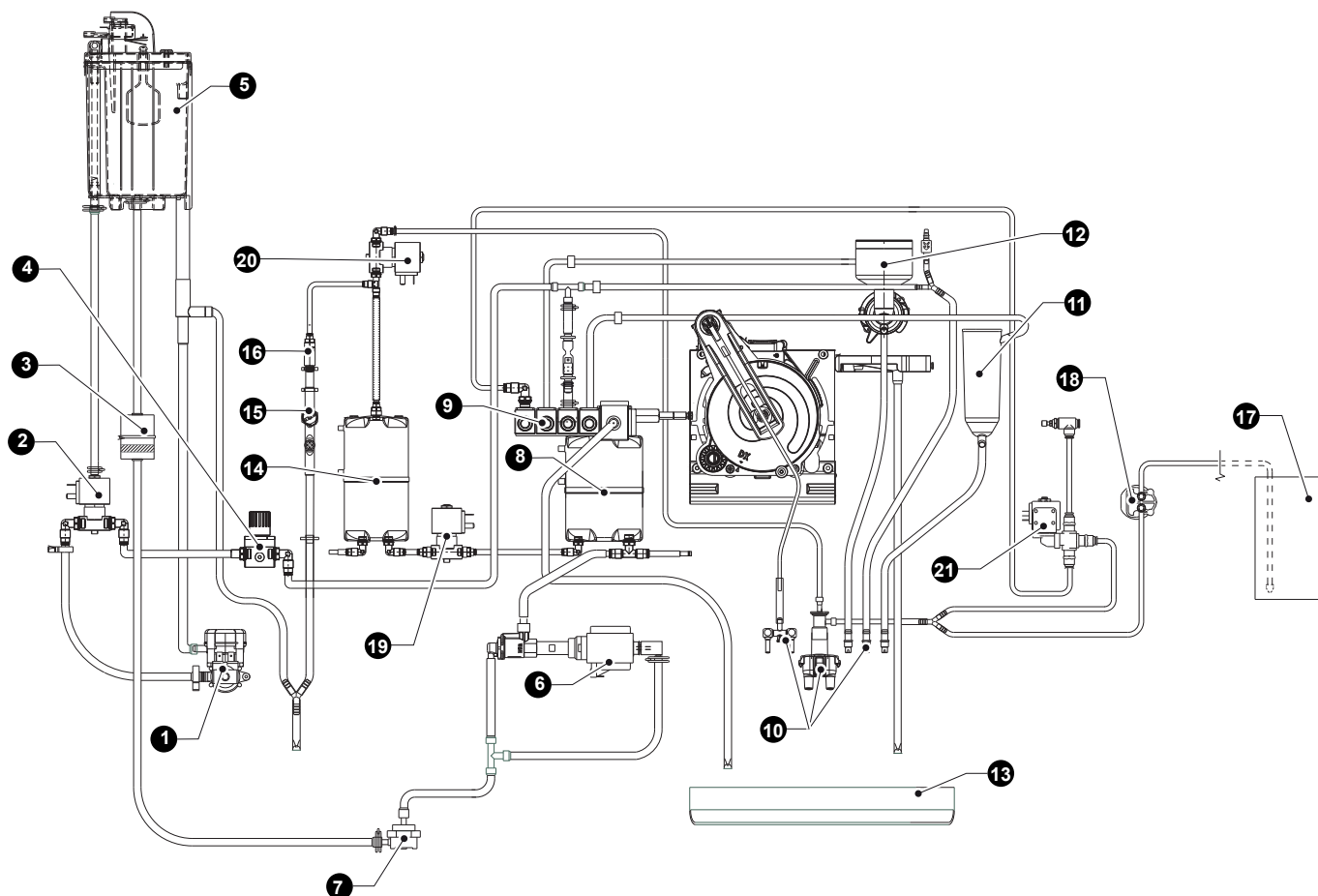

1. mains water solenoid valve
2. mixer solenoid valve
3. filter
4. pressure reducer*
5. air break
6. pump
7. flow meter
8. boiler
9. solenoid valves
10. dispensing nozzles
11. diffuser nozzle

12. mixer
13. liquid residue container
14. steam boiler
15. thermostat
16. safety valve
17. milk tank
18. milk pump
19. steam boiler filling solenoid valve
20. steam solenoid valve

* for models with a mains water mixer only

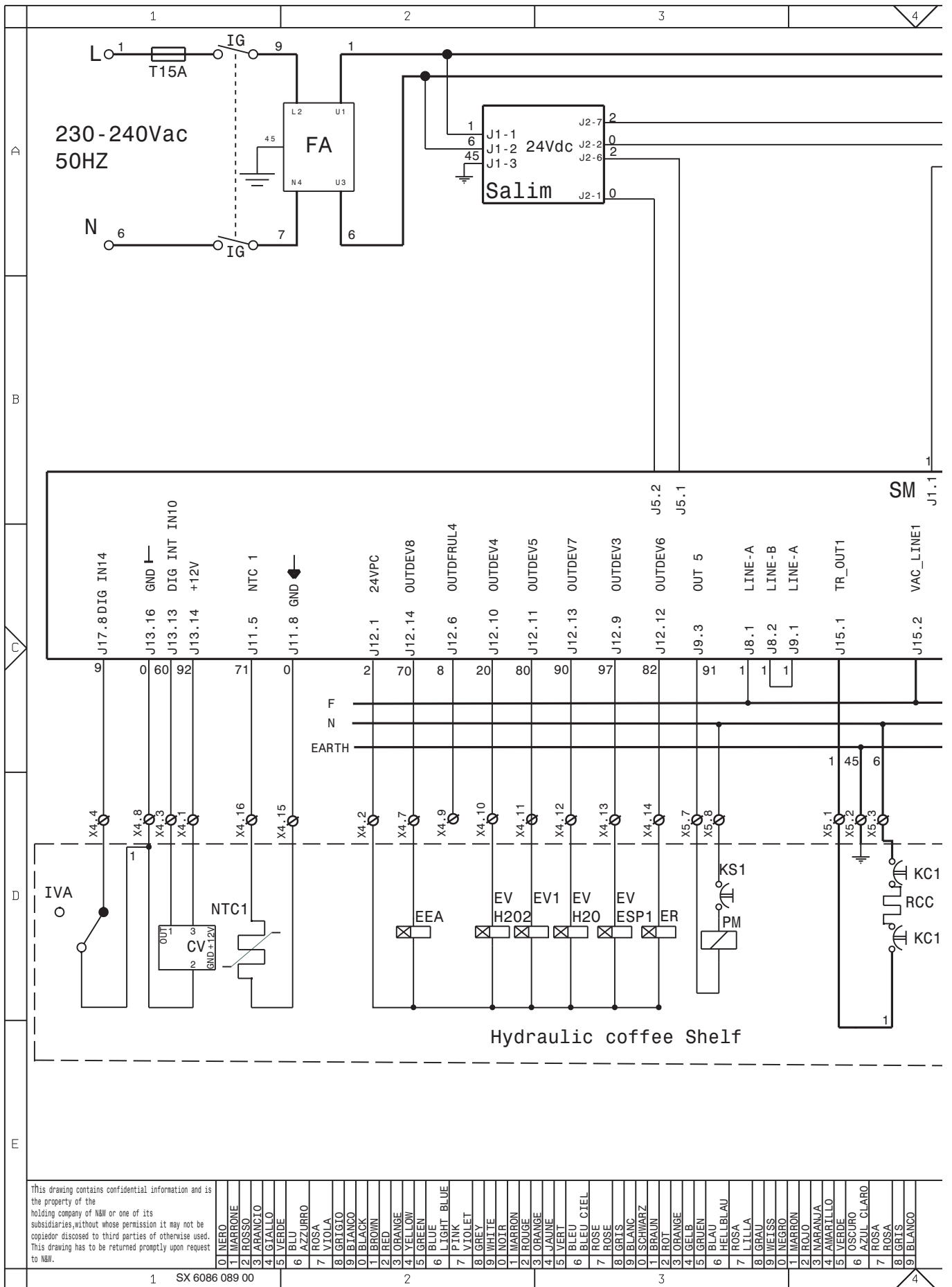

CCG GENERAL COUNTER
 CV VOLUMETRIC COUNTER
 EEA WATER INLET SOLENOID VALVE
 EEAVAP WATER INLET SOLENOID VALVE FOR STEAM
 ER COFFEE DISPENSING SOLENOID VALVE
 ESP1- DRAIN SOLENOID VALVE
 EVH2O WATER SOLENOID VALVE
 EVPINZ HOSE CLAMP SOLENOID VALVE
 EVVAP STEAM SOLENOID VALVE

EVWMLK CAPPUCCINO DISPENSER WASH SOLENOID VALVE
 FA RADIO INTERFERENCE SUPPRESSOR
 IG MAIN SWITCH
 KC1-.. COFFEE BOILER CUTOUT
 KS1-.. SAFETY CUTOUT
 NTC TEMPERATURE PROBE
 PM PUMP
 PMMLK MILK PUMP
 RCC COFFEE BOILER HEATING ELEMENT

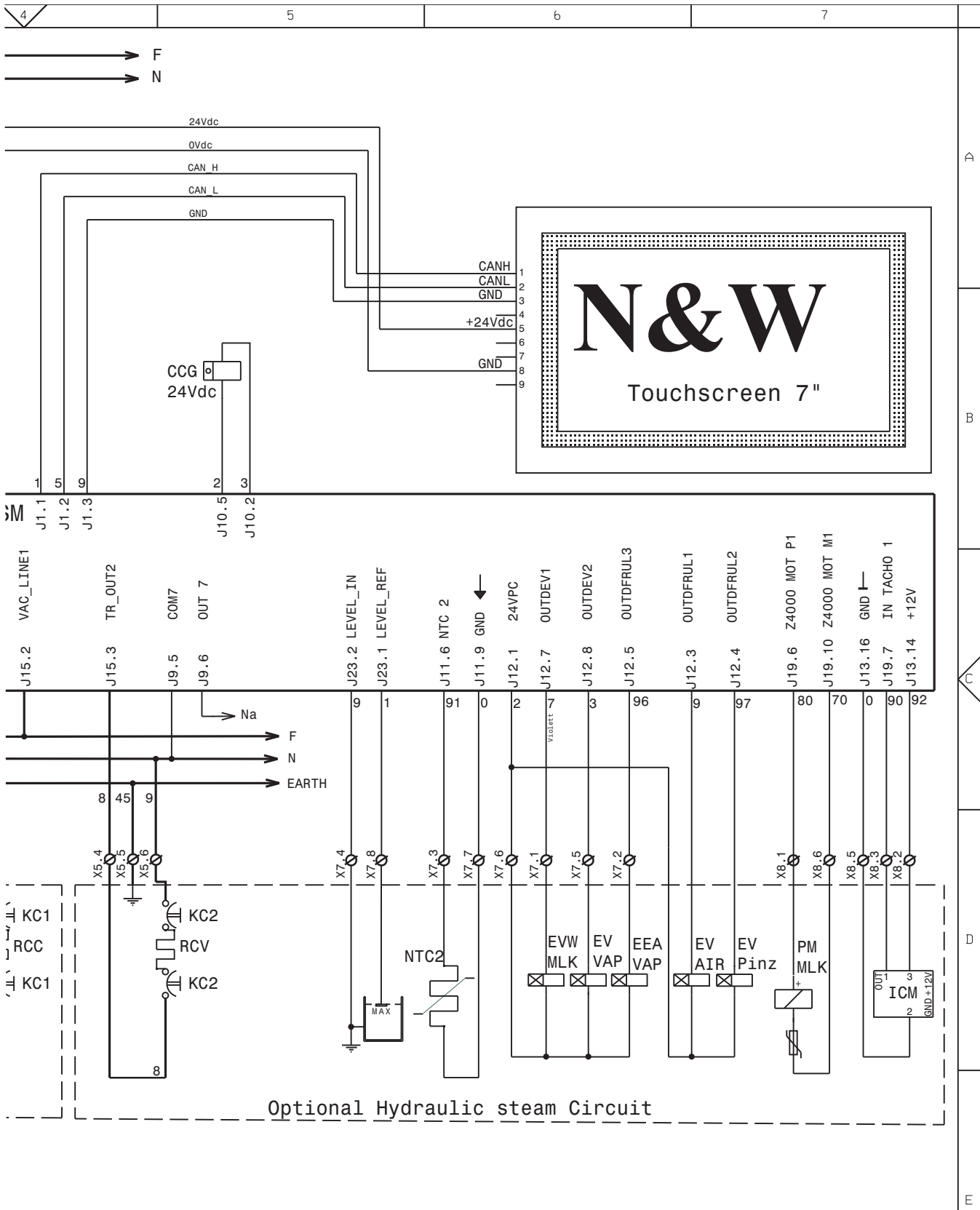

91 90 89 88 87 86 85 84 83 82 81 80 79 78 77 76 75 74 73 72 71 70 69 68 67 66 65 64 63 62 61 60 59 58 57 56 55 54 53 52 51 50 49 48 47 46 45 44 43 42 41 40 39 38 37 36 35 34 33 32 31 30 29 28 27 26 25 24 23 22 21 20 19 18 17 16 15 14 13 12 11 10 9 8 7 6 5 4 3 2 1	MODEL Kalea	DEFINITION SCHEMA ELETTRICO WIRING DIAGRAM	DATE 22/02/2017	SHEET 1/1	PREPARED RATTI	CHECKED RATTI	
	N&W GLOBAL VENDING S.p.A. Valbrembo - Italia			LEGENDA -	PART NUMBER 608608900		VERSION

RCV STEAM BOILER HEATING ELEMENT
 SALIM POWER SUPPLY UNIT BOARD
 SM MACHINE BOARD
 TX... DELAYED FUSE (X=CURRENT)

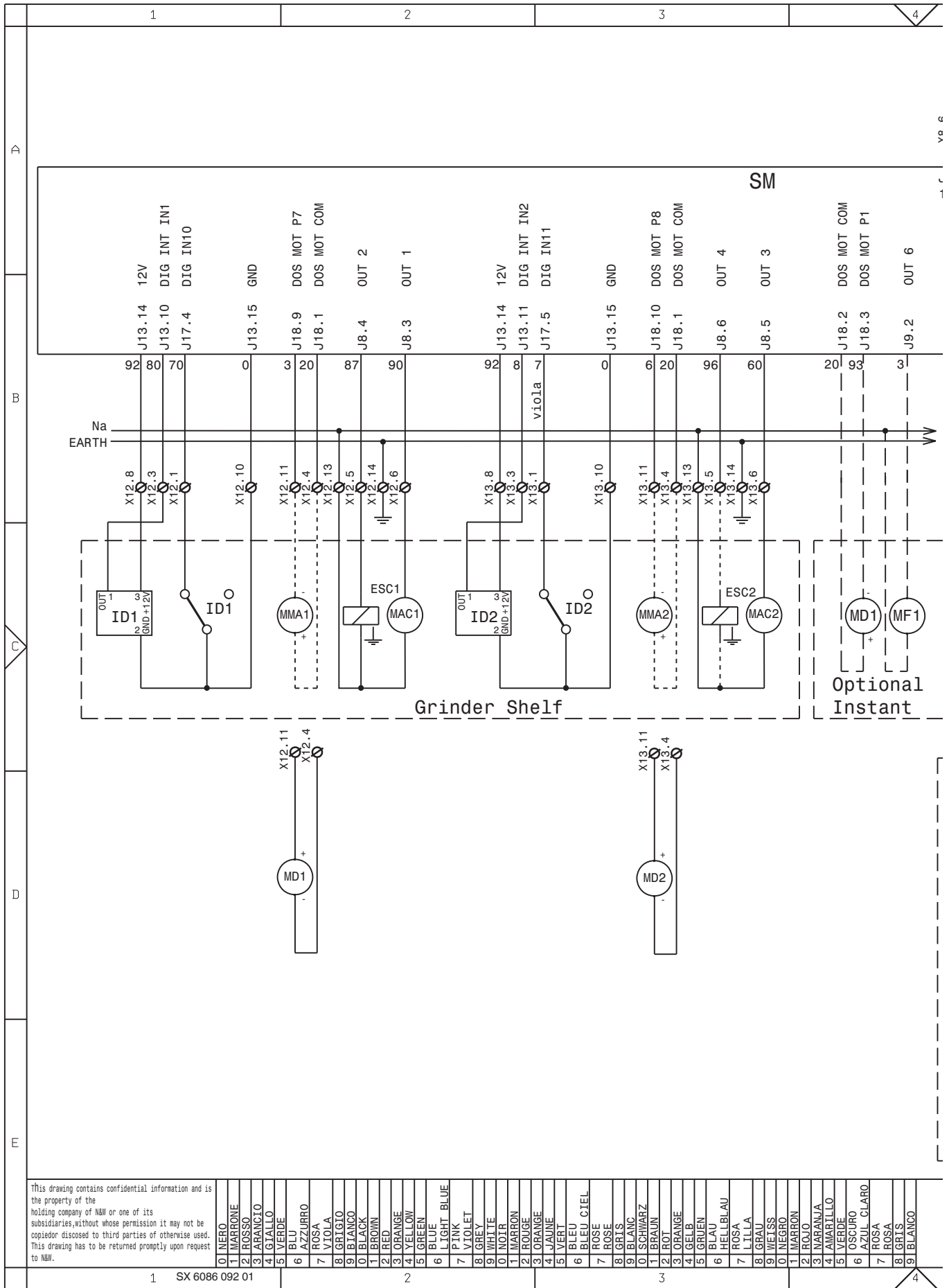

CM MOTOR CAM
ESC1- COFFEE RELEASE ELECTROMAGNET
ICM MOTOR CONTROL SWITCH
ID1-.. COFFEE DOSE SWITCH
IDEC DECAFFEINATED DOOR SWITCH
M COFFEE UNIT MOTOR
MAC1- COFFEE GRINDER
MCAF1. COFFEE CONTAINER PRESENCE MICRO
MD1-.. INGREDIENT MOTORS

MF1-.. INSTANT WHIPPER MOTORS
MFND SOLID RESIDUE CONTAINER MICRO
MIP DOOR MICROSWITCH
MLQD LIQUID RESIDUE CONTAINER MICRO
MMA1- GRINDING REGULATION MOTOR
MSOL1. INSTANT CONTAINER PRESENCE MICRO
SLED LED BOARD
SM MACHINE BOARD
VENT FAN

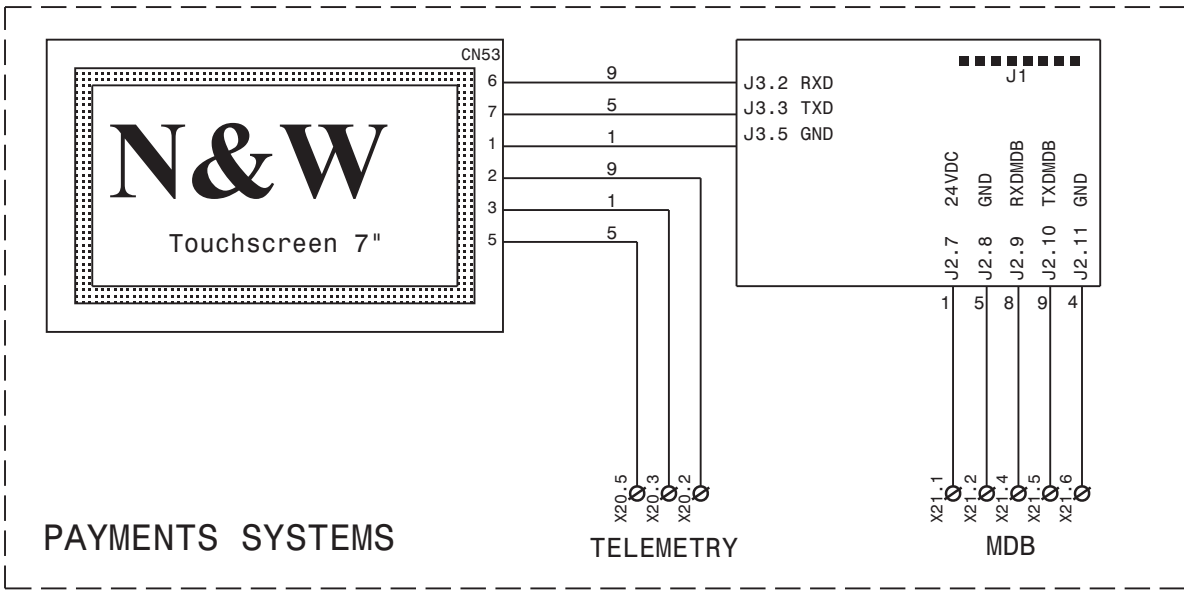
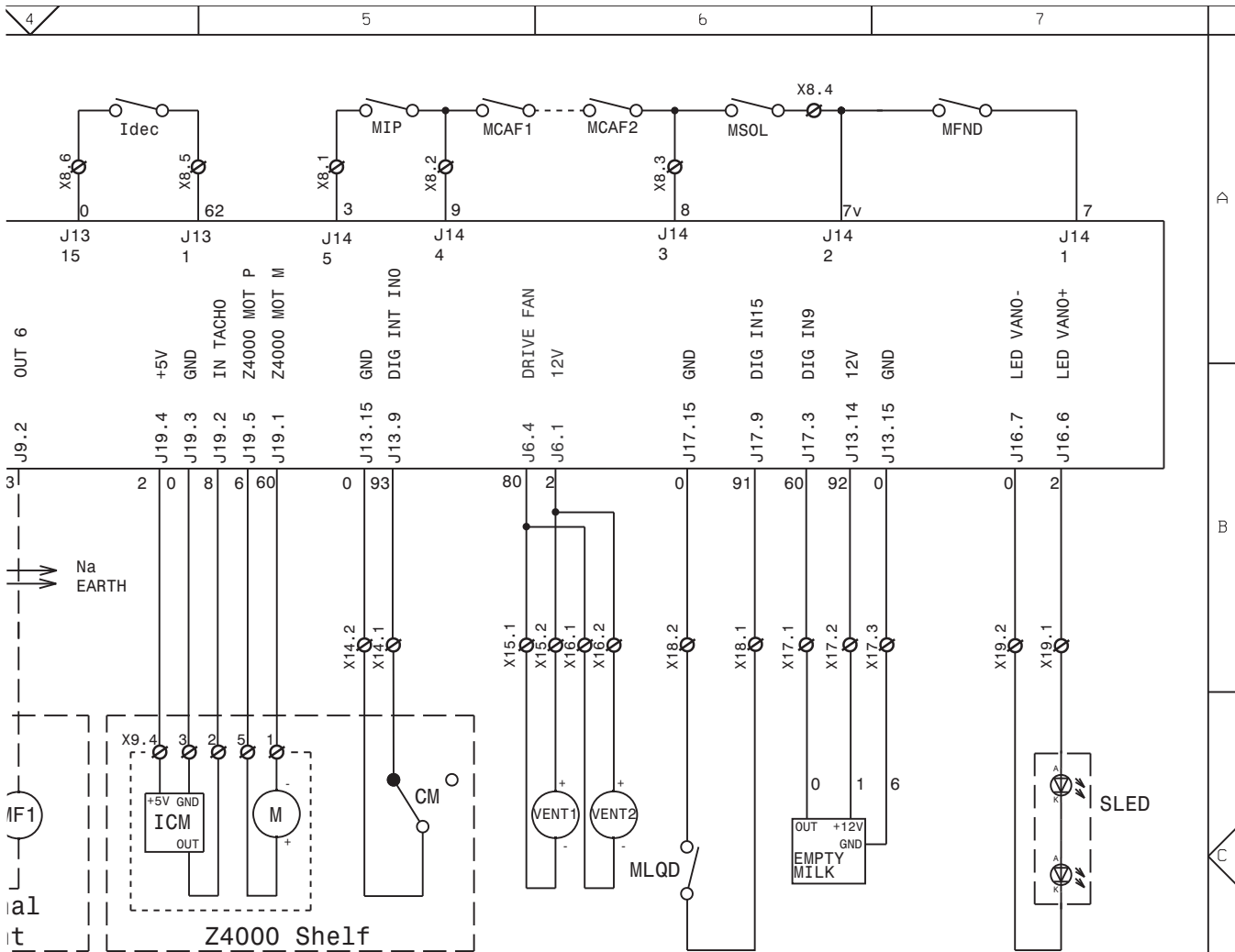

N&W GLOBAL VENDING S.p.A. Valbrembo - Italia	MODEL Kalea	DEFINITION SCHEMA ELETTRICO WIRING DIAGRAM	DATE 15/02/2016	SHEET 1/1	PREPARED RIPAMONT	CHECKED CORTINI
			LEGENDA -	PART NUMBER 608609201		VERSION

The manufacturer reserves the right to modify the features of the appliance described in this publication without prior notice; and furthermore declines any responsibility for any inaccuracies contained in this publication which can be ascribed to printing and /or transcription errors.

All the instructions, drawings, tables and information contained in this publication are confidential and can neither be fully or partially reproduced, nor transmitted to third parties without the written permission of the manufacturer, who is the exclusive owner.

